

Broadcast news

Volume No. 138, March 1968

CFTO-TV Color Production of
Shakespeare's "King Henry V"

TRGM

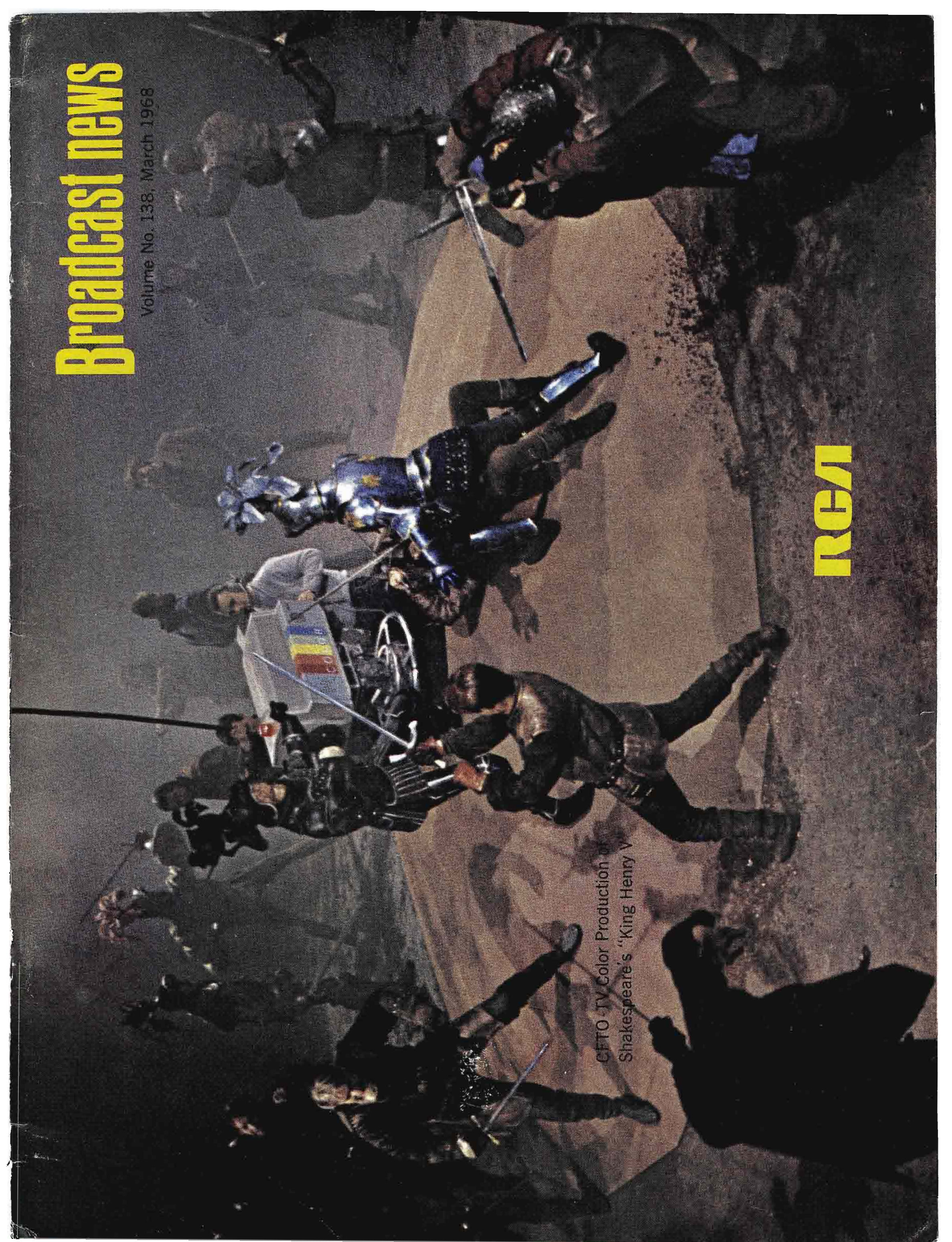



"Noiseless" Colors

**Tape the color "toughies...
play them like live"**



**...With the RCA TR-70
High Band Recorder**

The TR-70 is the high band television tape recorder for unexcelled performance. It's truly the world's most sophisticated system . . . it makes even the tough jobs in taping easy to accomplish. It delivers up to four generations of *brilliant, broadcastable color* without a trace of tattle-tale grain.

"NOISELESS" COLORS . . . even with yellow—the "noisiest color" around—you'll get a noise-free picture. The TR-70 delivers the greatest, most noise-free yellow you've ever seen—yellow, without even a whisper!

RCA

Broadcast

NEWS

Published by BROADCAST AND TELEVISION EQUIPMENT DEPARTMENT
RCA COMMERCIAL ELECTRONIC SYSTEMS DIVISION

CONTENTS

Editing Quadruplex Tape	4
“Butterfly” VHF Panel Antenna	8
KHVH-TV Live Color Pick-up	17
Shoot The Moon with the TK-43	18
CFTO Sets New Standards for Excellence in Color	24
Racing in the Rain Tests TK-42	32
Return-Beam Vidicon System	36

PRICE . . . single copies. \$2.50 each . . . \$12.00 for 6 issues

Copyright 1968 Radio Corporation of America. All Rights Reserved

RCA
TR-50

We've taken the

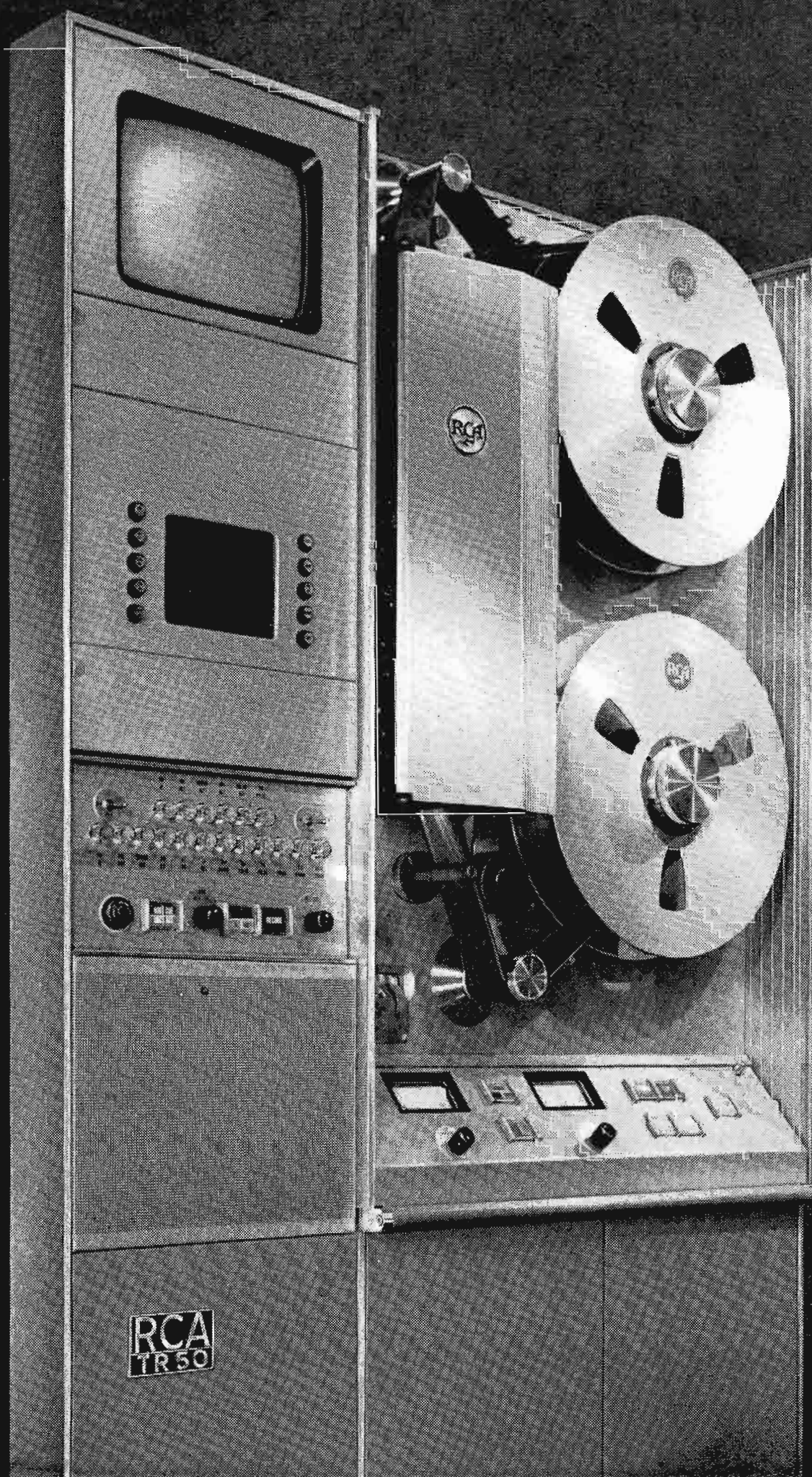

bite out of high band with the TR-50!

Today's lowest cost tape machine with high band color *performance*.

Here's the newest member of the RCA tape line. This recorder is designed for high band color *performance* with all the snap and sparkle that your clients can ask for . . . plus economy. The TR-50 is the most economical high band color recorder available today.

High band *performance*—43 db signal-to-noise and 40 db moire—has been achieved at the lowest price ever. This is a result of borrowing some of the advanced technology from the most deluxe TV tape recorders. For instance the FM Modulator—a heterodyne type—is the same as used in the RCA TR-70.

Words or specifications can only begin to describe the excellent high band performance of this machine. The real proof is in the picture . . . and *you can see it* for yourself in any of the stations that have it, in the Camden color demonstration area, or at the forthcoming NAB Convention.

For further information about this low-priced high band recorder, call your RCA Broadcast Representative. Or write RCA Broadcast and Television Equipment, Building 15-5, Camden, New Jersey 08102.

RCA Broadcast
Equipment

EDITING QUADRUPLEX TAPES

PETER A. DARE
Television Tape Merchandising

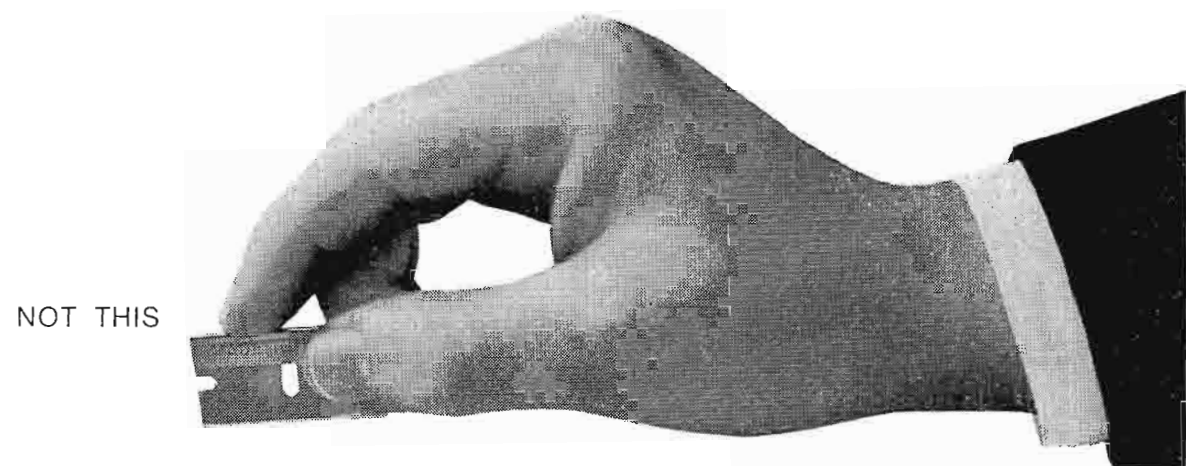
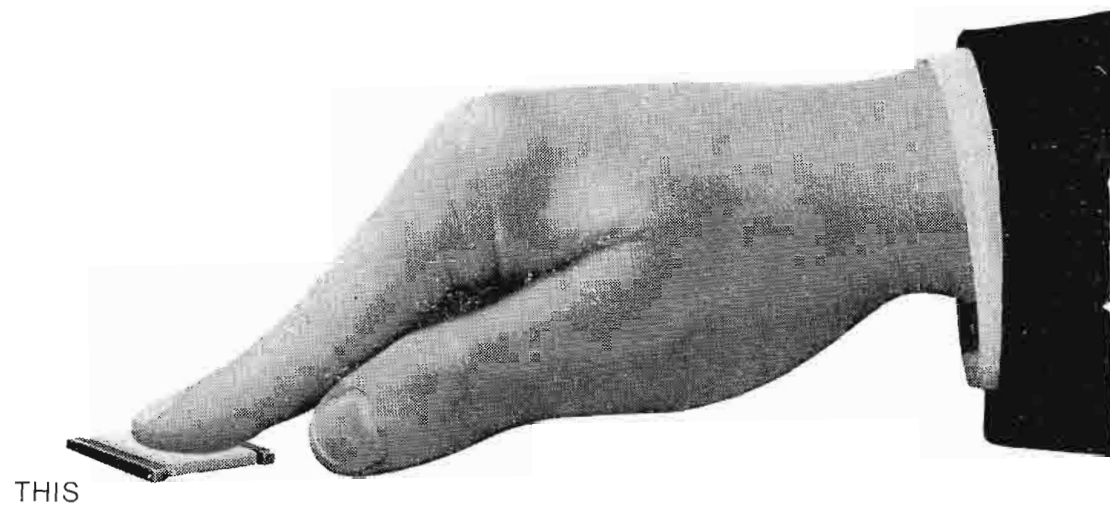

FIG. 1 Electronic methods replace the razor blade.

The ability to edit or splice is one of the prime requirements of any storage medium used in pre-recording TV programs. It is essential that a producer be able to eliminate actors' mistakes, build a program from short sections of previously recorded material, and create animation type effects. To achieve this with video tape requires splicing the tape, physically or electronically.

Mechanical Splices

Chronologically, the physical or mechanical type of splice was the first to be attempted. This splice is performed by cutting two sections of tape and accurately rejoining them with a thin, pressure-sensitive tape. Splice points are determined optically after "developing" a section of tape by depositing small iron particles on the tape. The resultant patterns formed by the magnetized tape are used as a guide in determining the correct point to cut the tape.

Mechanical vs Electronic Splices

With the introduction of the electronic splicer, splices can be made purely on an electronic basis. The tape is not cut, and control over many parameters that affect the quality of the splice is provided. To make

an electronic splice the most that ever has to be done is to place 3 switches in the correct position and push a button.

A better appreciation of the differences between mechanical and electronic splicing will be apparent after some of the parameters that affect the performance of a splice are considered. These parameters include:

1. Headwheel Phase
2. Sync Generator Reference
3. Control Track Phase
4. Recording Radius and Guide Height
5. Video and Audio Level

Color vs Monochrome

The magnitude of the errors that can be tolerated in color splicing must be a great deal smaller than the tolerable errors in monochrome. For color, the combination of all errors must not introduce any more than one microsecond of ATC error when the splice is replayed. Should the error exceed one microsecond, varying degrees of disturbance occur, the severity of the disturbance being associated with the servo replay mode. The Line Lock Only replay servo mode is the most tolerant replay servo available for handling splice timing errors.

In monochrome, errors of 30 microseconds may be tolerated before any subjective disturbance is noticed. As in the color mode, the severity of the disturbance is related to the replay servo mode; the Tonewheel and Switchlock modes are the most tolerant of large timing errors. As the degree of control over the headwheel phase is increased, the susceptibility to any timing errors is also increased.

Headwheel Phase

For the purpose of editing, headwheel phase can be related to the position of the vertical interval on the tape as shown in Fig. 2A. To this position a tolerance has to be applied which is related to servo stability as indicated by the stability markers that appear on the tape machine video monitor. Figure 2B is an exaggerated illustration of what can happen if the incoming sync is not stable or the servo stability is poor. The only controls there are over headwheel phase are the servo setup adjustments, plus those that are established on the headwheel itself in the record mode.

With mechanical splicing, it is nearly impossible to achieve the degree of timing accuracy required for color replays. In fact, the tape editor really has very little, if any, control over the resultant timing at the splice point. It is a hit and miss effort. With the electronic splice, a different situation exists. A knob is provided that permits near perfect matching of the newly recorded headwheel phase to that of the original recorded phase (See Fig. 3).

vided that permits near perfect matching of the newly recorded headwheel phase to that of the original recorded phase (See Fig. 3).

Sync Generator Reference

The sync generator essentially controls the speed of the tape in the record mode. When recording a video source locked to a sync generator which is referenced to a monochrome crystal, the field rate is 60 Hz; however, if that same generator is referenced to the color standard, the field rate becomes 59.94 Hz. As a result the physical tape speed changes between the two recordings. This change is not normally sufficient to cause any trouble. However, if the speed change approaches 0.3 percent variation, then a physical splice will lose tracking at the splice point. In the case of the electronic splice, it is possible to correct for this type of trouble by properly setting up the capstan oscillator frequency.

Control Track Phase

Using the electronic splicer, compensation can be made in the electronic splice mode to correct for any small discrepancies. However, with mechanical splicing, no compensation is practical. Hence, if the error is too large, a mistracking effect will be seen at the splice point. The control track phase is normally adjusted with the use of the RCA alignment tape or by following

FIG. 2 (a) Diagram showing correct position of the vertical interval; (b) exaggerated effect of poor servo or sync generator stability on the position of the interval.

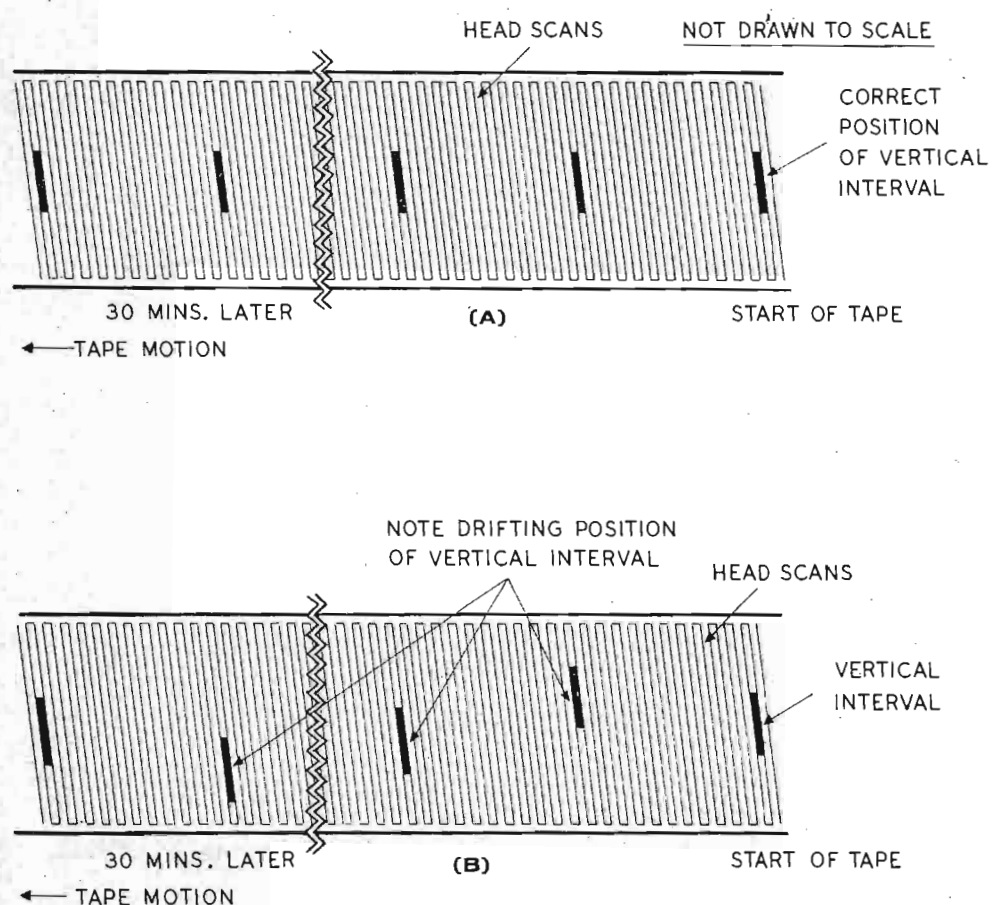
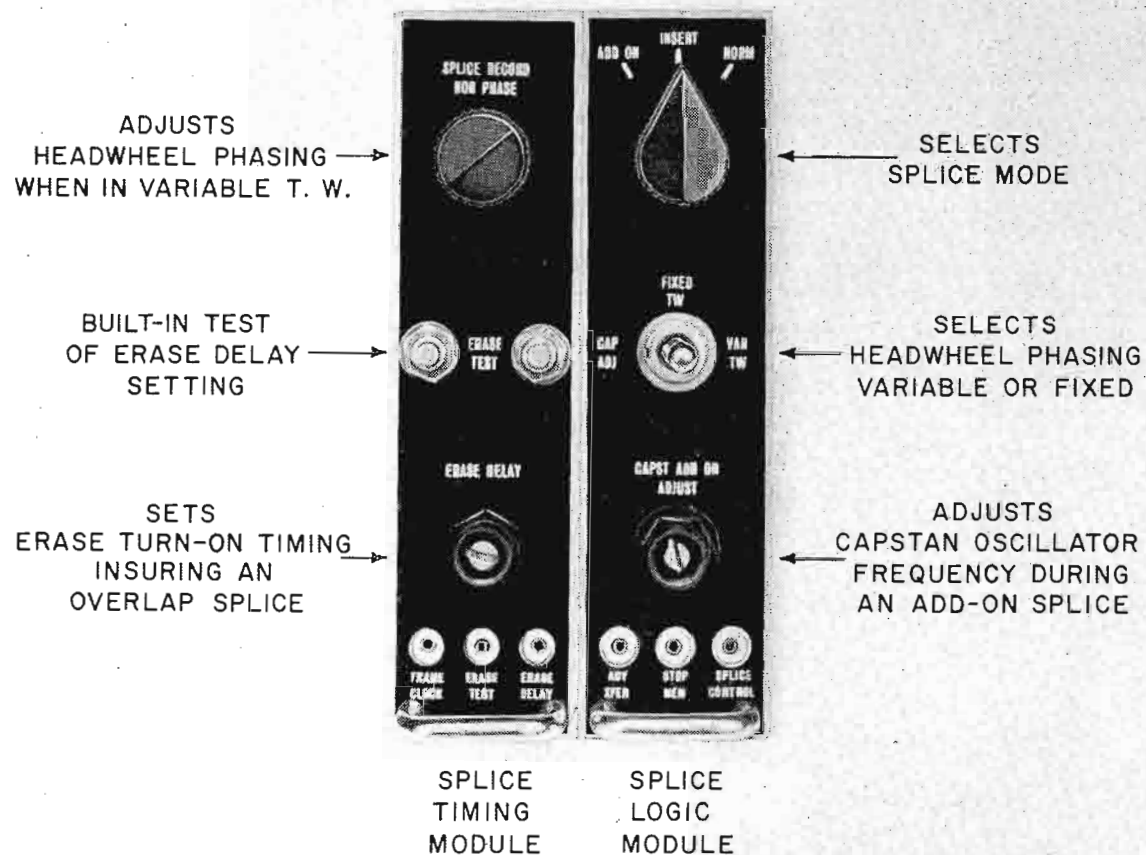

FIG. 3 Front views of Splice Timing Module and Splice Logic Module identifying the controls and their functions.



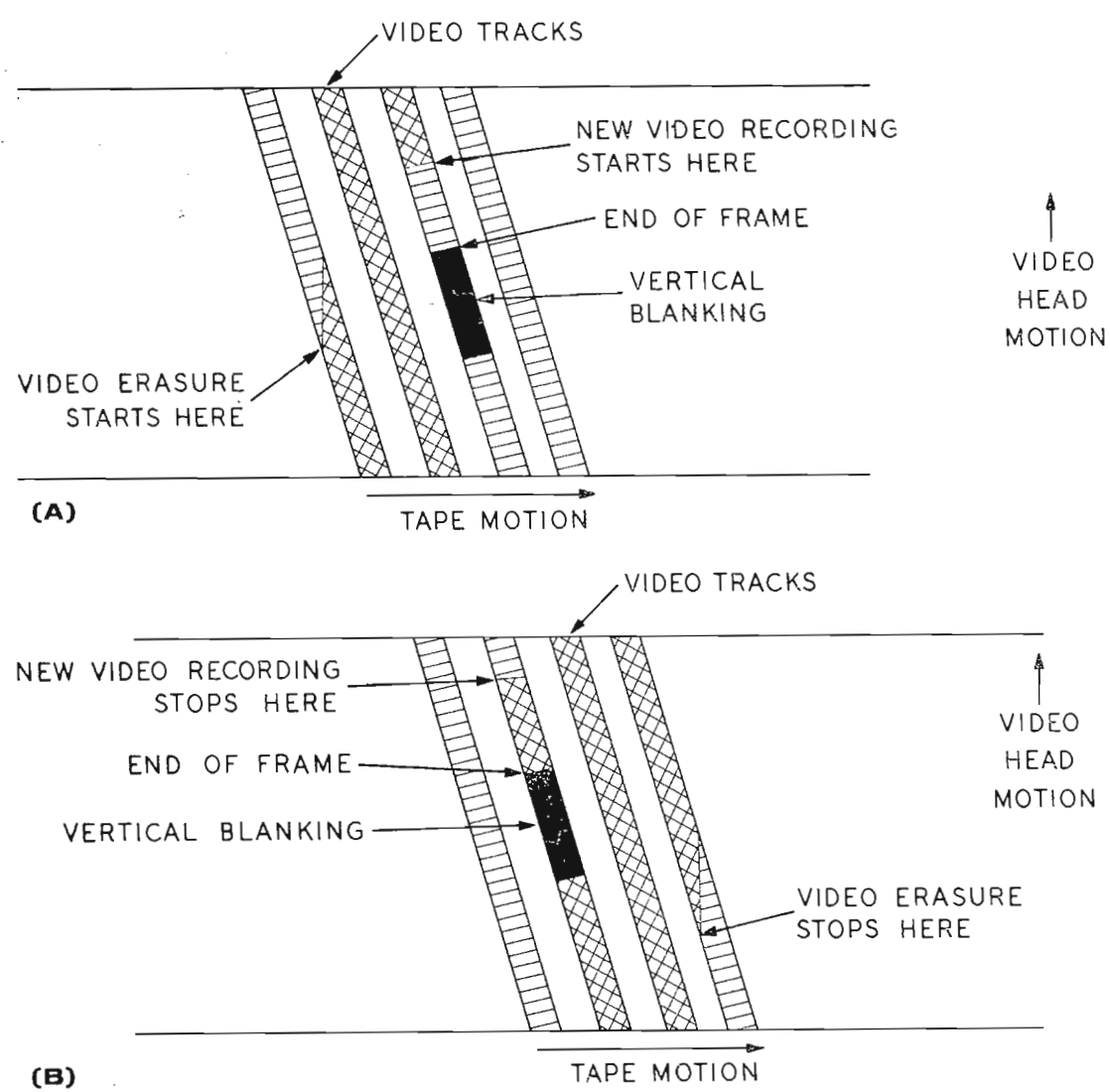

FIG. 4 (a) Typical ingoing splice; (b) typical outgoing splice.

the instructions outlined in the appropriate instruction book.

Recording Radius and Guide Height

In mechanically splicing two sections of tape together, it is highly desirable to have the record radius and guide height adjustments the same. If this is not the case, color banding may well result, and if the error is severe enough, the ATC and CATC will be unable to cope with the error with a resultant color disturbance. When using an electronic splicer, this situation need never exist; complete control of the segment-to-segment adjustments can be maintained, eliminating this source of trouble.

Video and Audio Levels

What may seem a very minor point can detract greatly from what may have been an excellent edit. With mechanical splicing, reliance for constant levels is placed upon the studio technical director and his ability to recall his previous average picture level. The process of electronic editing greatly reduces the problem of matching levels as the tape operator can preview a tape prior to the splice and adjust levels accordingly.

Other parameters present problems or considerations of a much lesser nature. It can be seen, however, that with an electronic splicer the operator has the oppor-

tunity to correct for timing and level defects and thus insure reliable splices even under the most adverse conditions. Further, tape stock and headwheel life are not impaired by handling, and there is less likelihood of poor splices. It has been proven that headwheel life may be reduced considerably with the passing of poor mechanical splices through the machine.

What is an Electronic Splicer?

The electronic splicer is basically a system of counters that control the on and off switching of various machine functions. One may ask why all functions cannot be switched on and off at once. The answer is quite clear when you consider that the erase head for the video tracks is some $7\frac{1}{2}$ inches away from the record head. This corresponds roughly to one-half second in real time. If all functions were to be switched simultaneously, bursts of tape noise and severe signs of poor erasure would exist for one-half second intervals during an ingoing and outgoing splice.

Electronic Splicer Modes

Two modes of operation are provided for on the electronic splicer. One is designated "Add On," the other is "Insert." The Add-On mode is used when a section of material has to be added to a previously recorded program. In this mode a new control track is recorded in addition to the new video.

The insert mode is used when a previously recorded segment requires some change to be made to it. This mode retains the original control track. The other major differences between the Add On and Insert mode is the functioning of the counters. In the Add On mode the counters only are required to perform one splice, an ingoing splice. When using the Insert mode, the counters are required to perform two splices, one ingoing and one outgoing.

What Does an Electronic Splice Look Like?

Typical ingoing and outgoing splices are shown in Figures 4A and 4B. It can be seen that the new or spliced video starts or ends near the top of a track containing vertical sync. Also, it can be seen that a small unerased section exists in both splices on which the new recordings overlap the old. The overlaps are deliberately created to allow for differences between the machines on which the two recordings are made. These overlaps will produce no subjective or measurable disturbance.

Set-Up

The set-up of the electronic splicer is very simple; all the necessary signals are available at test points throughout the machine. Perhaps the most interesting waveform is that produced by the erase test position. By depressing two buttons on the splicer modules, an artificial erase signal is pulsed on and off. By viewing the FM switcher output on the scope, the precise erase timing can be seen and adjusted if necessary for the $1\frac{1}{2}$ tracks of overlap (See Figs. 5 and 6).

Effects of Poor Splicing

Two noticeable effects are noted when poor splices pass through a machine. The first is a loss of tracking (See Fig. 7) that shows on a picture as "cross talk" from an adjacent head scan. The second is loss of servo lock that manifests itself as a loss of picture stability for up to three seconds. In the preceding paragraphs, the cause for poor splices have been outlined. For almost every condition, the ability of the Electronic Splicer to correct for these conditions is far greater than the control that can be exercised over mechanical splices; therefore, the reliability of splicing with Electronic Splicer is one of the major advantages of using the electronic form of splicing.

Splicer Installation

Any RCA TR-70/TR-22/TR-50/TR-4 or TR-5 can be equipped with an electronic splicer. In early model machines, some rewiring is required; however, for latter model machines, usually 30 minutes is all that is required to install and set up the splicer to the point where you are ready to carry out a full series of edits.

FIG. 5 FM switcher output waveform (SW OUT) on CRO with ERASE TEST button held down (High Band machine).

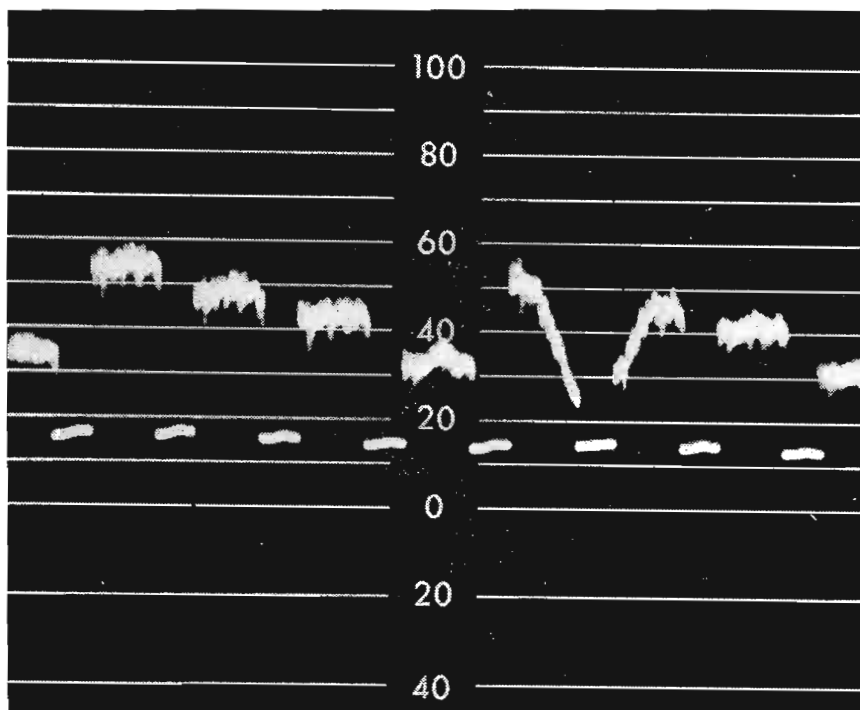
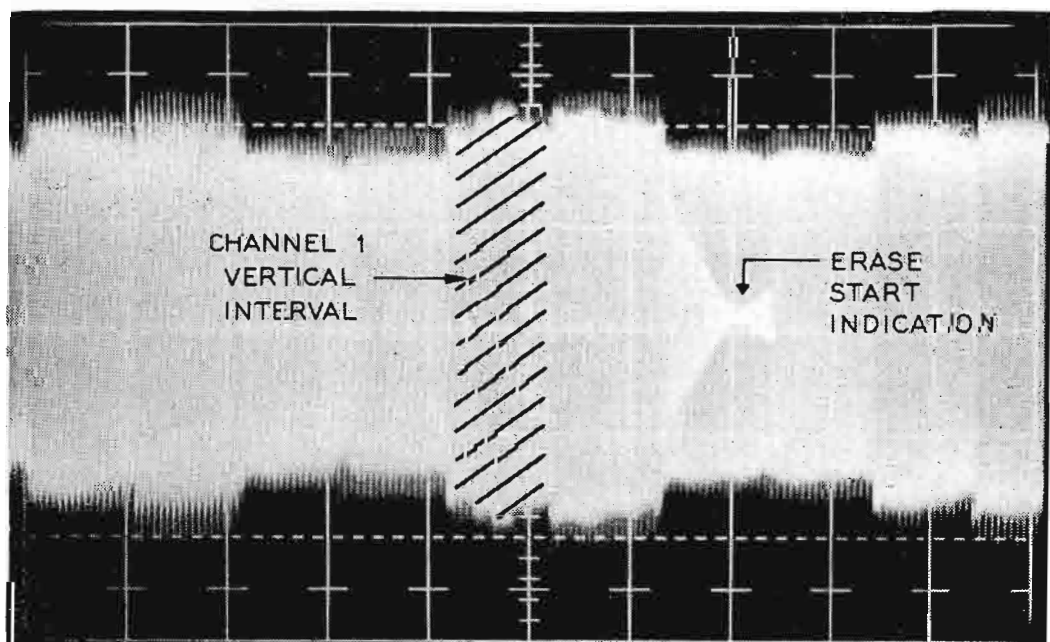

FIG. 6 FM LEVEL waveform on CRO with ERASE TEST button held down (Low Band machine).



525/625 Color or Monochrome

Providing the timing errors are kept to a minimum, the splicer is capable of splicing either monochrome or color signals. The color signals can either be NTSC coded or PAL coded. Likewise, on machines equipped with switchable standards, the splicer will operate on 525/625/405 or 819 lines. Where $7\frac{1}{2}$ IPS operation is employed, the counters in the electronic splicer circuitry sense this and apply the necessary changes in timing automatically to compensate for the difference between 15 IPS and $7\frac{1}{2}$ IPS operation.

FIG. 7 Diagram showing track spacing tolerances and likely effects of mechanical splice. Electronic splicing does not affect track spacing at the splice point.

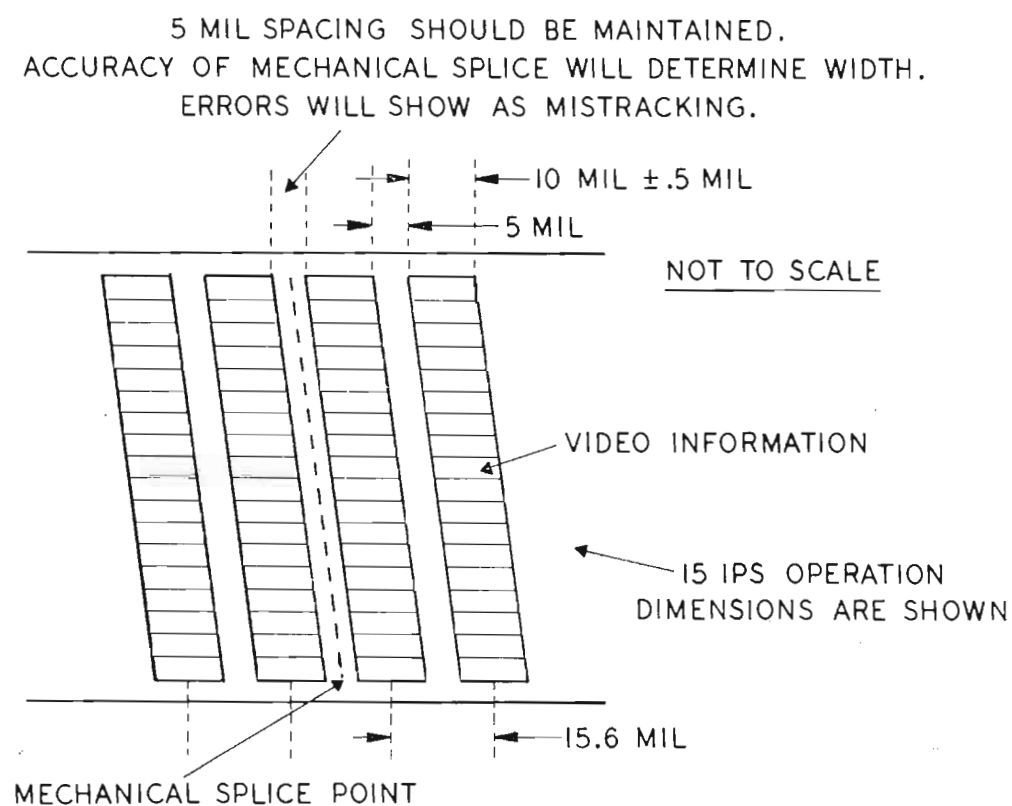

In addition to the above, safety features are built into the electronic splicer that virtually make it foolproof. Inhibit gates prevent the splicer from operating in the incorrect servo mode. Warning lights inform the operator as to what mode he is in. Other safety features are employed that are related to the machines' operational modes.

Conclusions

Examples of the use of an electronic splicer can be seen daily: Assembly of news programs, highlights of football matches, promotional material for station breaks, production effects on television tape commercials and many others. The use of an electronic splicer makes splicing reliable and easy to perform without need for a highly skilled television tape editor. In nearly all applications, the electronic splicer is capable of doing a better job than the mechanical splicer, while preserving tape and headwheel life.

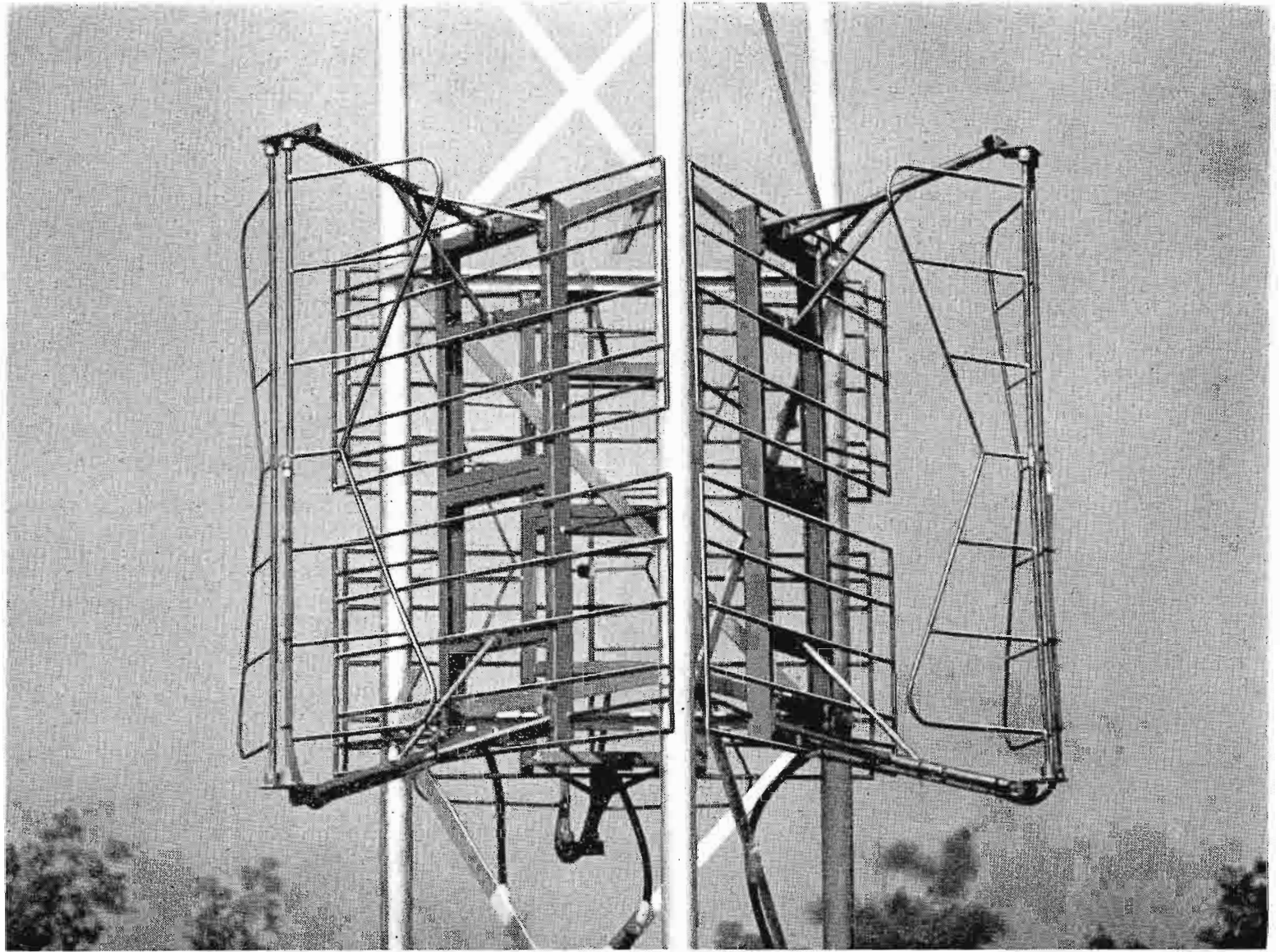
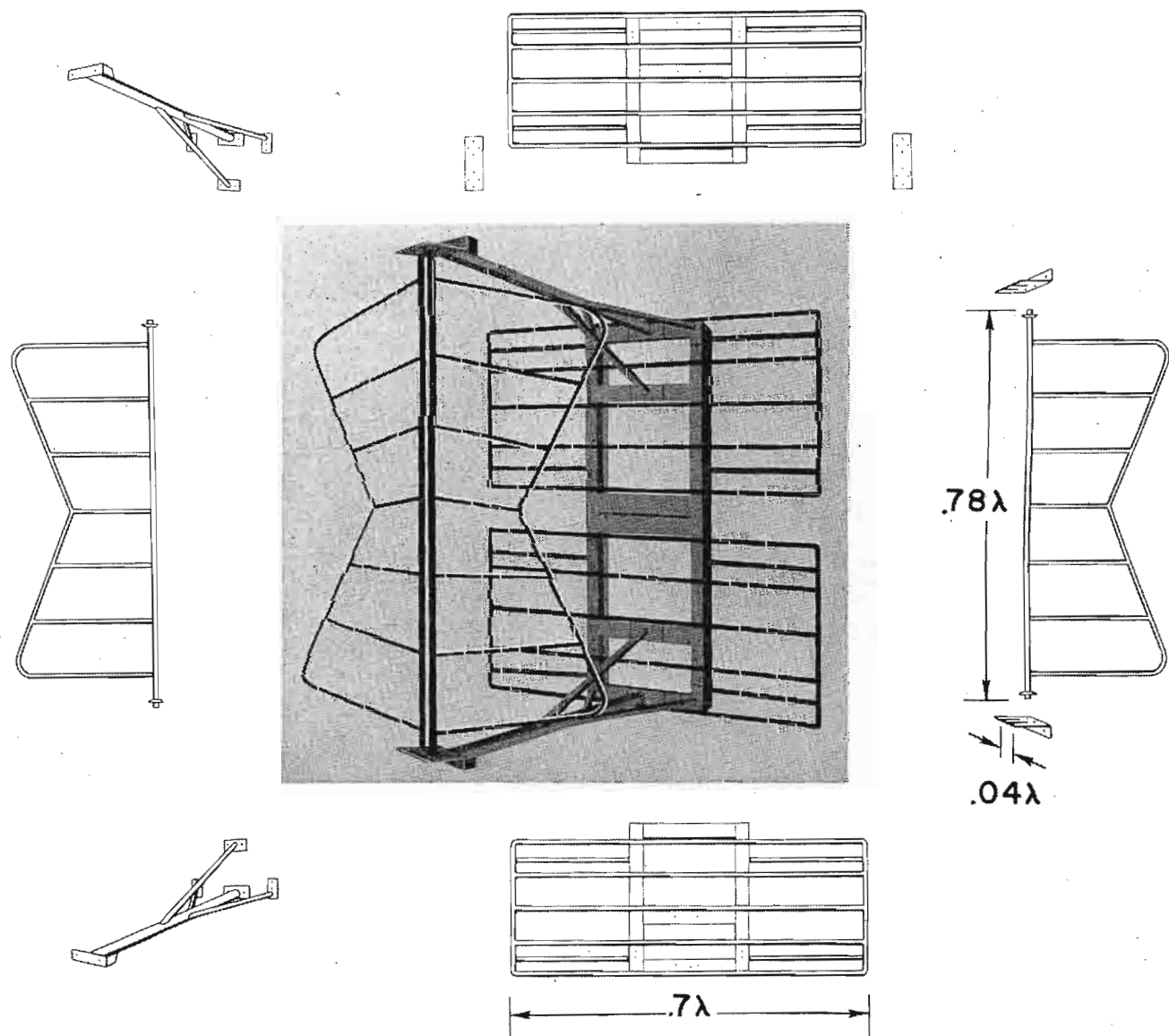

FIG. 1 Test Model of the "Butterfly" Antenna made up of three panels mounted around a triangular tower structure. Optimum impedance and radiation characteristics are achieved by positioning the "wings" backward.

FIG. 2 Exploded view of the antenna showing its separate parts and wave-length dimensions.



An increasing need for stacked arrays, face-mounted antennas and directional radiation patterns has produced such VHF antennas as the Supergain and Zee Panel, however the latest in this line is the "Butterfly." This represents a new development, combining some of the best features of the Superturnstile with the mounting and pattern-shaping flexibility of a panel antenna. Many will agree that the Superturnstile, after many years, is still the work-horse of VHF antennas. There are more than 600 of these RCA antennas in operation all over the world.

Design Simplicity

Figure 1 illustrates a test model of the new antenna made up of three panels mounted around a triangular tower structure. The "butterfly" radiating elements, which are seen to resemble the familiar "batwings" of the Superturnstile, are positioned backward toward the screens to provide the optimum impedance and radiation characteristics. Mechanical rigidity and strength are achieved by direct metallic support of the radiating element to the screen, and the screen to the supporting tower.

"BUTTERFLY" VHF PANEL ANTENNA

Affords A Simplified Approach to
Tailored Patterns

D. A. BRAUN
Antenna Development Engineer

B. K. KELLUM
VHF Antenna Product Specialist

Smaller Size and Lighter Weight

An exploded view of the panel showing its relative simplicity appears in Fig. 2. The supporting screen frame is made in two halves to meet the possible need for assembly of a panel on site where the resulting lighter weight would be of considerable advantage. As a result of the symmetry of the antenna, there are no currents in the screen perpendicular to the splice, and hence the splice is of no electrical significance.

The panel is made in three basic sizes; one each for the 54-66 MHz, 66-88 MHz and 174-216 MHz VHF bands. Typical dimensions in terms of wavelength are shown in Fig. 2. These will be recognized as similar to those of a Superturnstile. The complete screening frame is only 0.7λ square. Its size and construction have been found large enough for a reflector and adequate to prevent undue effect on the radiation pattern by hardware within the mast structure. This makes it considerably smaller than most panel antennas. The whole assembly, except for feedline and associated feed strap, is made of galvanized steel. A complete mid-band panel weighs about 750 pounds.

Proven Feed System

The Butterfly VHF Panel antenna employs Superturnstile feed system components, which are mounted inside the supporting structure. This proven feed system has demonstrated its reliability and long life.

The panel has a single feed point, and is fed by electrically connecting the outer conductor of a 77.5 Ohm feed line all the way up the riser of one of the

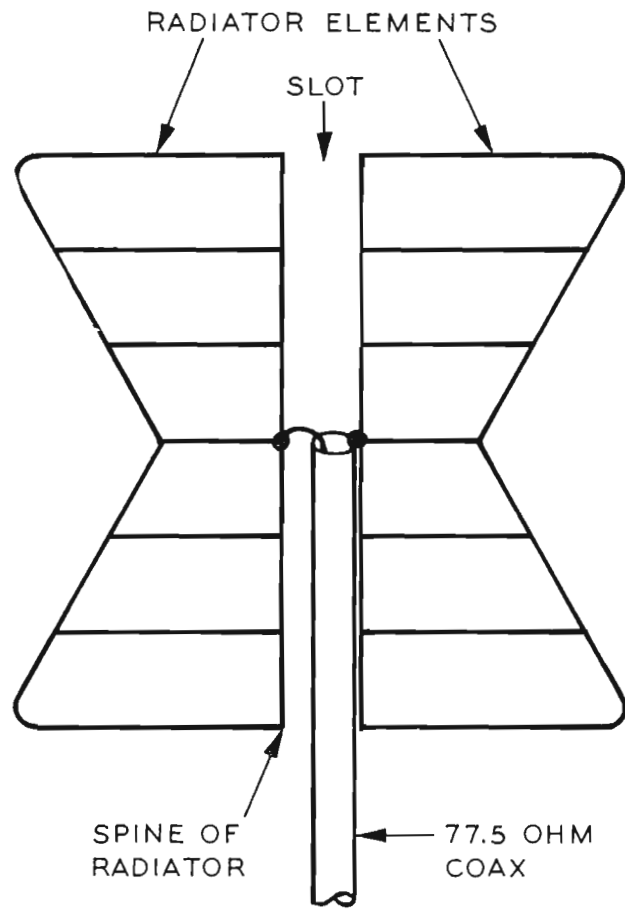

batwing elements to the midpoint of the slot (see Fig. 3). At this point, the line has an end seal that facilitates bleeding the feed line. A feed strap of plated phosphor bronze connects the inner conductor to the opposite side of the slot. This construction has proved reliable on Superturnstiles in the field. Another important feature of construction from the standpoint of lightning protection is that the complete radiating element is electrically grounded. Up to 12 panels can be fed from a single junction box as shown schematically in Fig. 4.

High Power Capability

For all practical purposes, the power handling capacity of a single panel is limited only by the feed line chosen. Typically, either $\frac{3}{4}$ inch or $\frac{7}{8}$ inch Styroflex

FIG. 3 Schematic of individual panel feed showing the outer conductor of the feed line electrically connected to the midpoint of the slot. The inner conductor is connected to the opposite side of the slot.

FIG. 4 Schematic diagram of a four-layer "Butterfly" Antenna using 12 panels fed from a single junction box.

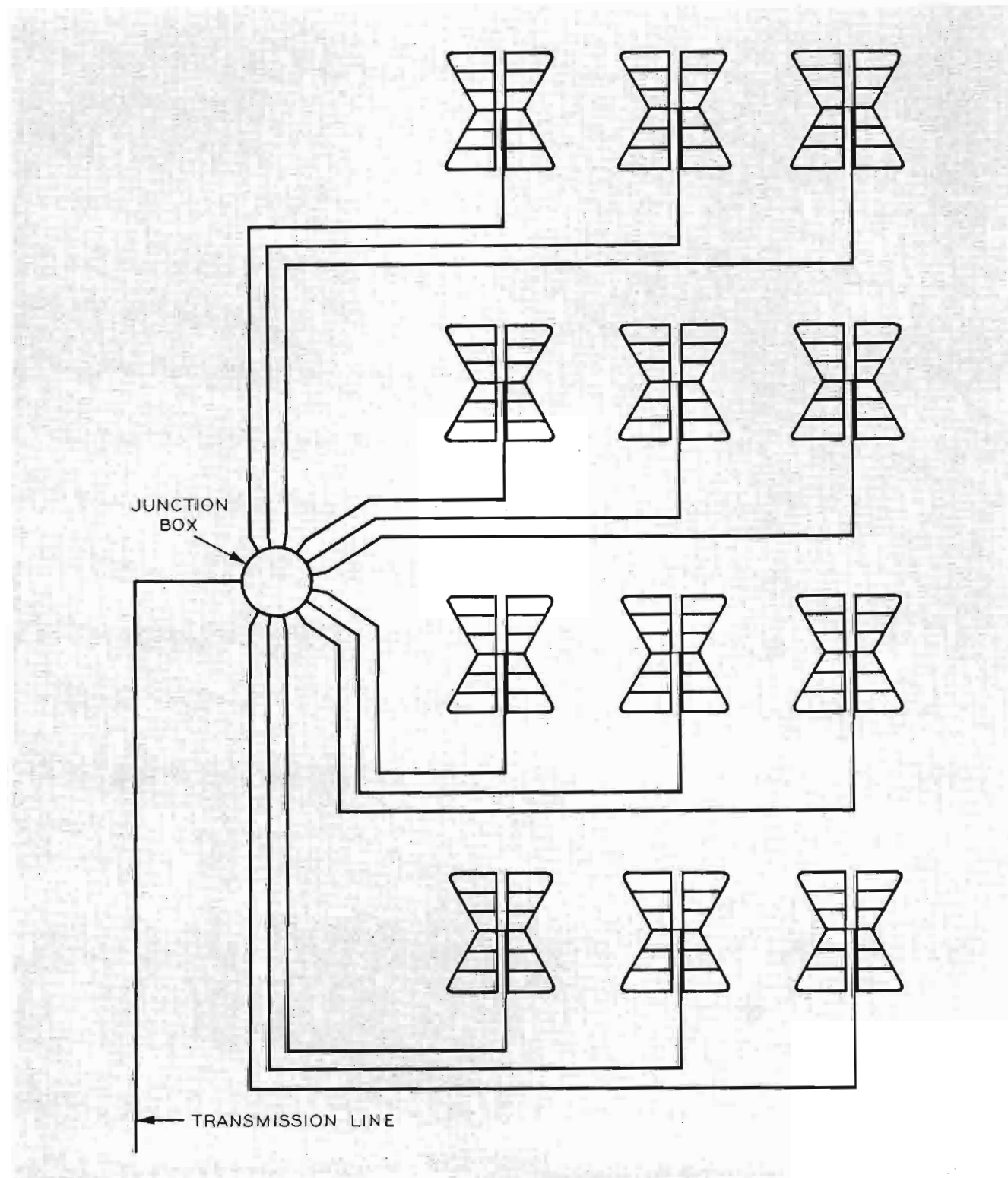

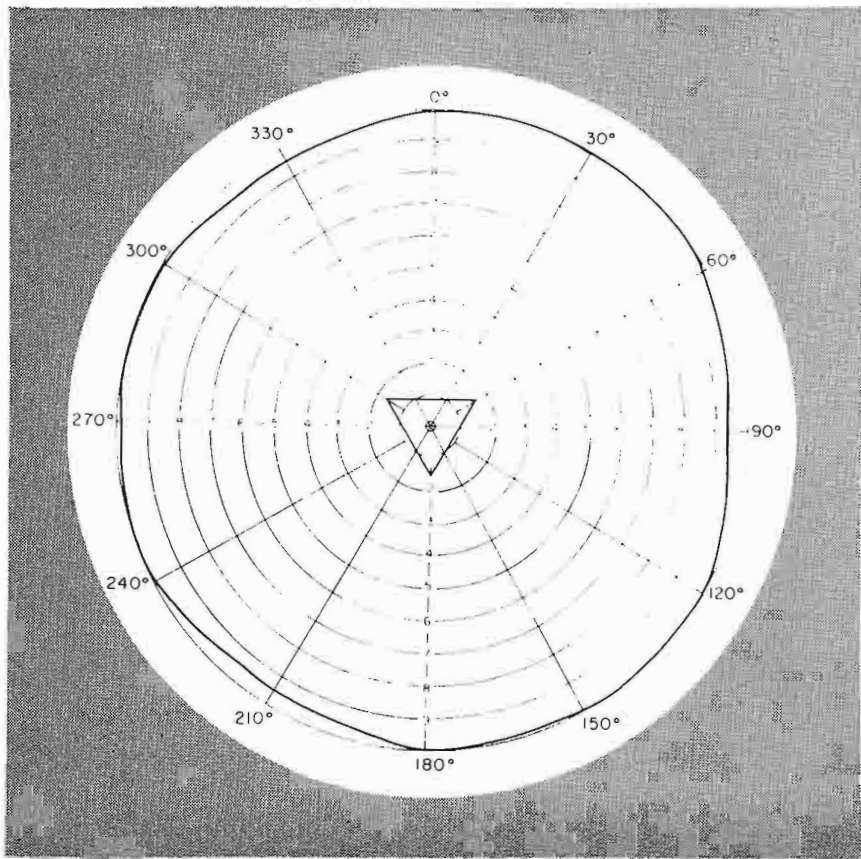

FIG. 5 Pattern obtained from a three-sided array with equal power division to all three panels giving a ± 0.25 dB omnidirectional pattern.

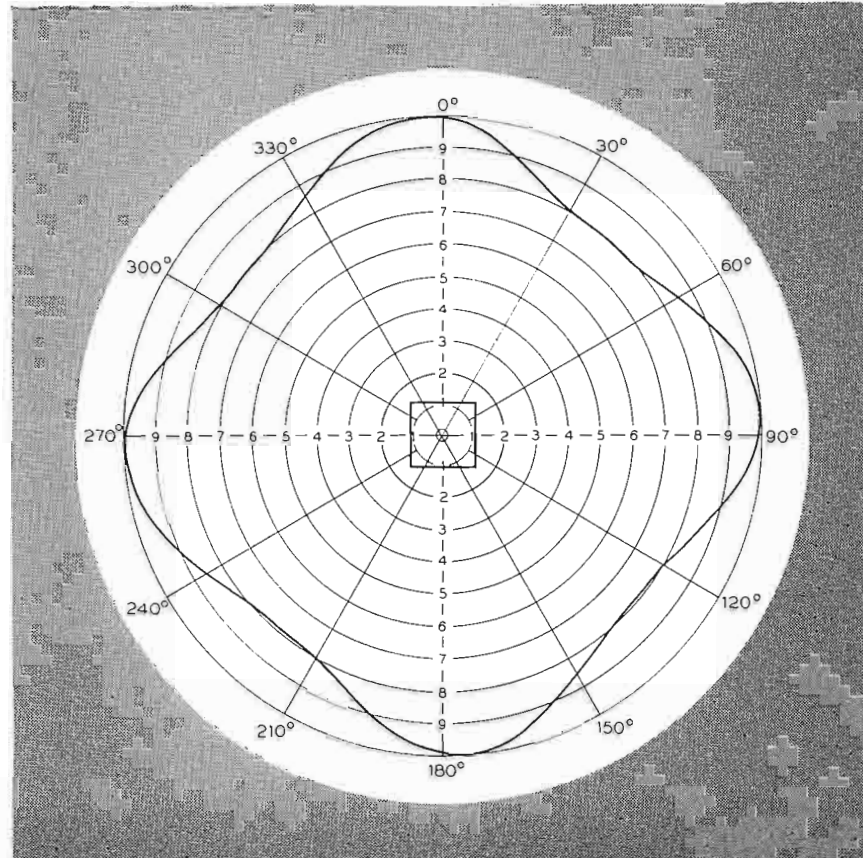

FIG. 7 Pattern obtained using four panels around a square tower resulting in an omnidirectional pattern with a maximum deviation of only ± 1.0 dB.

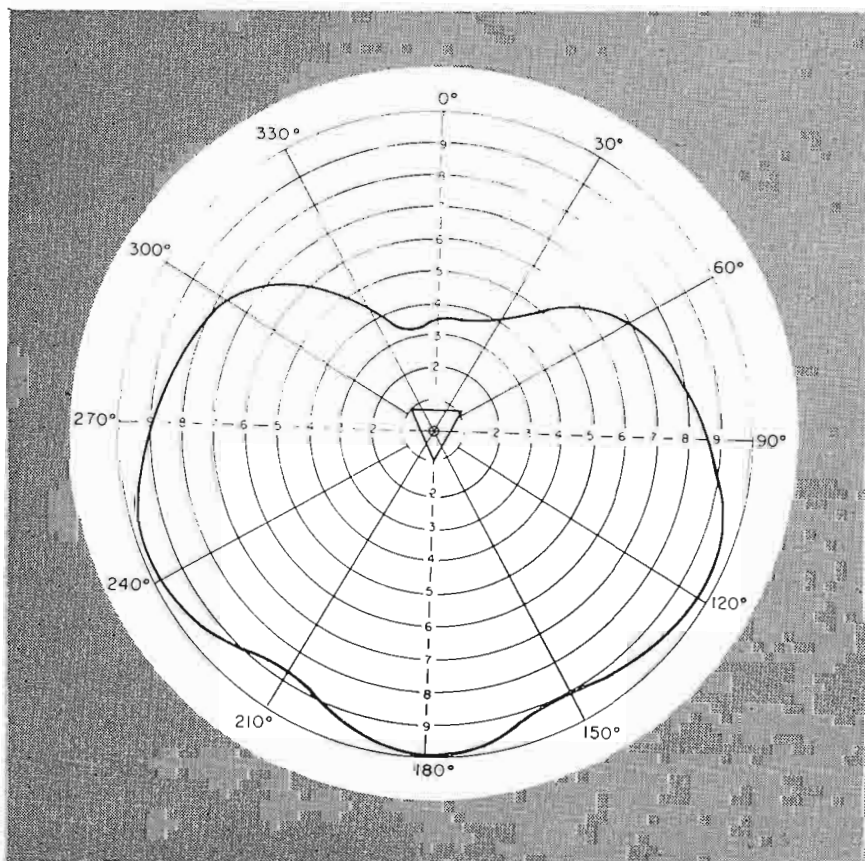

FIG. 6 Pattern obtained from a three-sided array with a 10 dB power division resulting in a cardioid pattern.

type line would be used. The $\frac{3}{4}$ inch size has an average power handling capacity of 1.75 kW, and the $\frac{7}{8}$ inch size handles 2.25 kW at 200 MHz.

De-icing

The normal method of de-icing the slot is by means of two heating elements, one in the riser of each radiator which is the successful method used with the Superturnstile. Power consumption is relatively low, amounting to 3 kW for an individual layer composed of three mid-band panels.

Tailored Radiation Patterns

The Butterfly VHF-TV antenna is well adapted to mounting three panels around a triangular tower. For certain requirements, such as for some directional applications, four panels mounted around in a square may be desirable.

An important electrical feature of the antenna is the influence that the angle between the butterfly elements has on the radiation characteristics. This, added to the usual variables of phase and power division, provides an effective adjustment for use in pattern-shaping.

Figures 5 through 8 show typical measured radiation patterns for three-sided and four-sided tower arrays. The antenna used in obtaining these patterns was a 6.5:1, mid-band precision scale model. The dimensions of the tower model represent a 7.5-foot face at the middle of the band.

Figure 5 shows a pattern obtained from a three-sided array with equal power division to all three panels, giving a ± 0.25 dB omnidirectional pattern. Fig. 6 shows a cardioid pattern given by a 10 dB power division. An example of a pattern obtained using four panels around a square tower is shown in Fig. 7. This is an omnidirectional pattern with a maximum deviation of only ± 1.0 dB having all panels fed in phase.

High-band VHF patterns are identical to the mid-band patterns when the model tower size is scaled down to conform to high-band dimensions. In other words, when the 7.5-foot tower is scaled down to about three feet. Even on the 7.5-foot tower face the high band antenna achieved circularity of better than ± 1.5 dB shown in Fig. 8. For vertical patterns, the Butter-

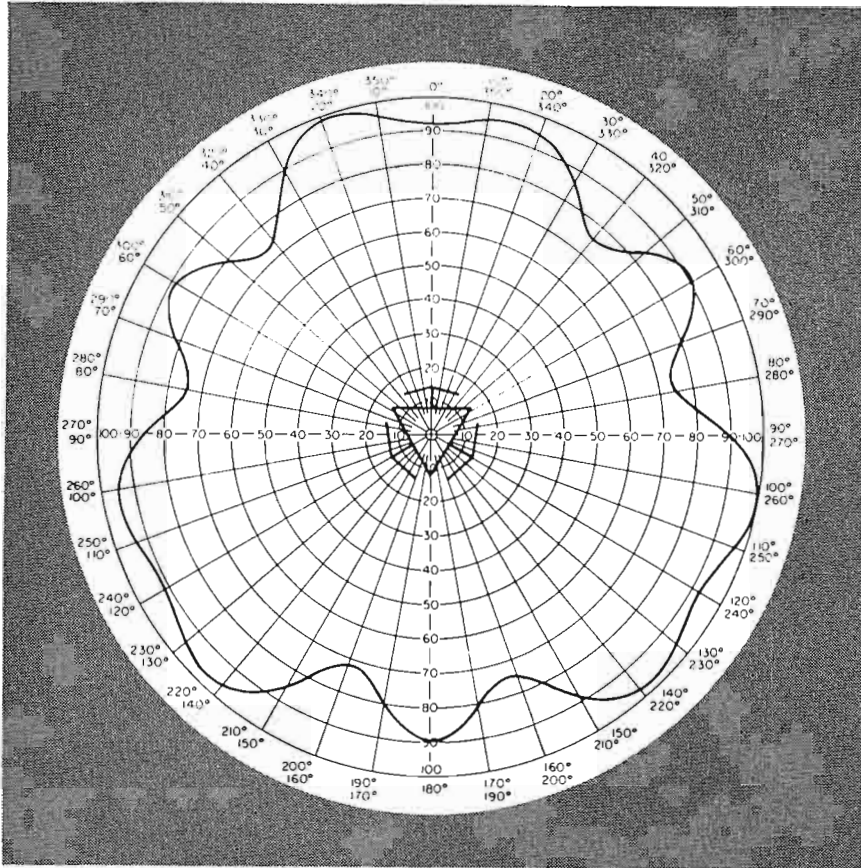

FIG. 8 Pattern obtained from a scaled down "Butterfly" model antenna for high-band VHF 174-216 MHz. showing a circularity of better than ± 1.5 dB.

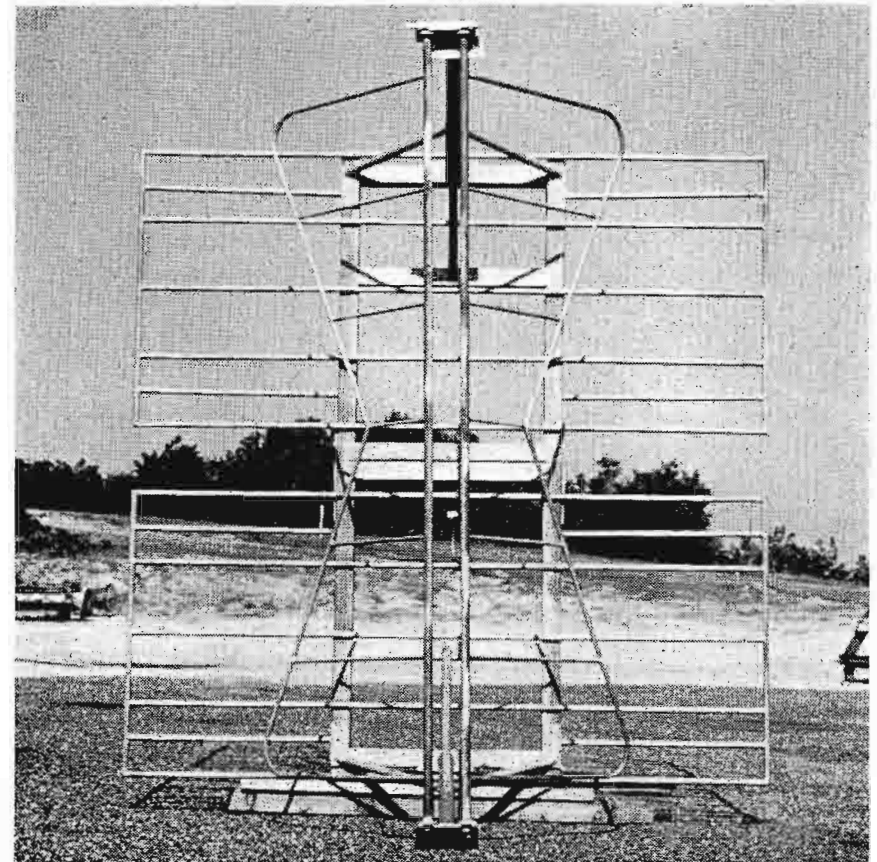

FIG. 10 Photograph of a full size mid-band "Butterfly" Panel Antenna. It is a rugged antenna with mechanical and electrical simplicity.

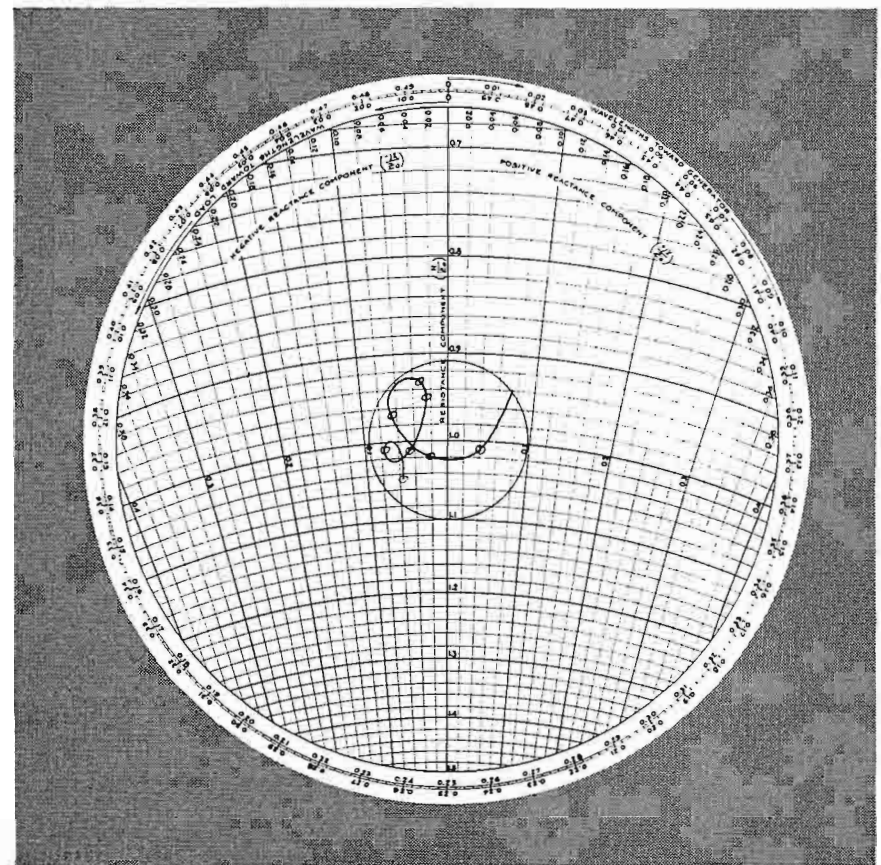
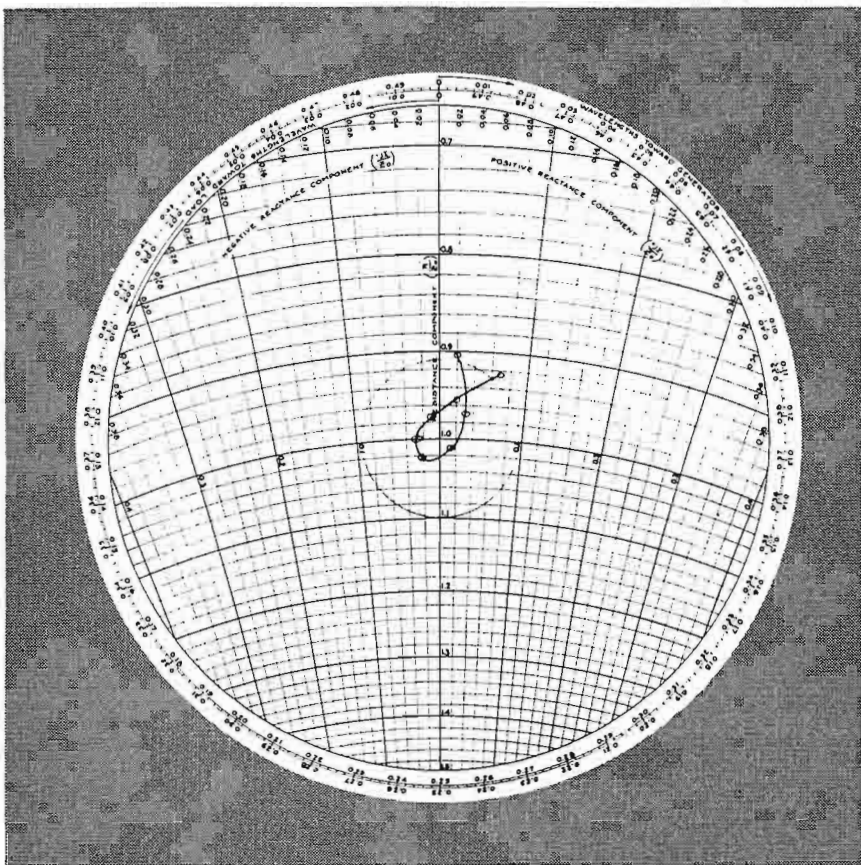

FIG. 9 Typical "Butterfly" impedance measurement Smith Chart plots made on a full size mid-band panel similar to that shown in Fig. 10.

fly antenna offers the same variety and flexibility as the Superturnstile.

Impedance Characteristics

The two arms of the expanded dipole form a series-parallel resonant circuit with a natural impedance bandwidth of some 20 percent using a VSWR of 1.1:1 as a criterion. This is illustrated by the typical Smith Chart Plots of impedance measurements of a single panel, shown in Fig. 9. These impedance measurements were made on a full size mid-band panel similar to that shown in Fig. 10. By trimming slot length and width for any specifically designed panel, the

usual television VSWR requirements can be achieved for any particular channel in the appropriate band.

Conclusion

The Butterfly Panel Antenna is a significant step forward in VHF antenna design. It is a rugged face-mounting system with mechanical and electrical simplicity, extreme flexibility and natural bandwidth. Utilizing time-proven components, it is certain to take a prominent place in VHF-TV by filling an important need, particularly for stacked, multiple antenna arrays and custom tailored radiation patterns.

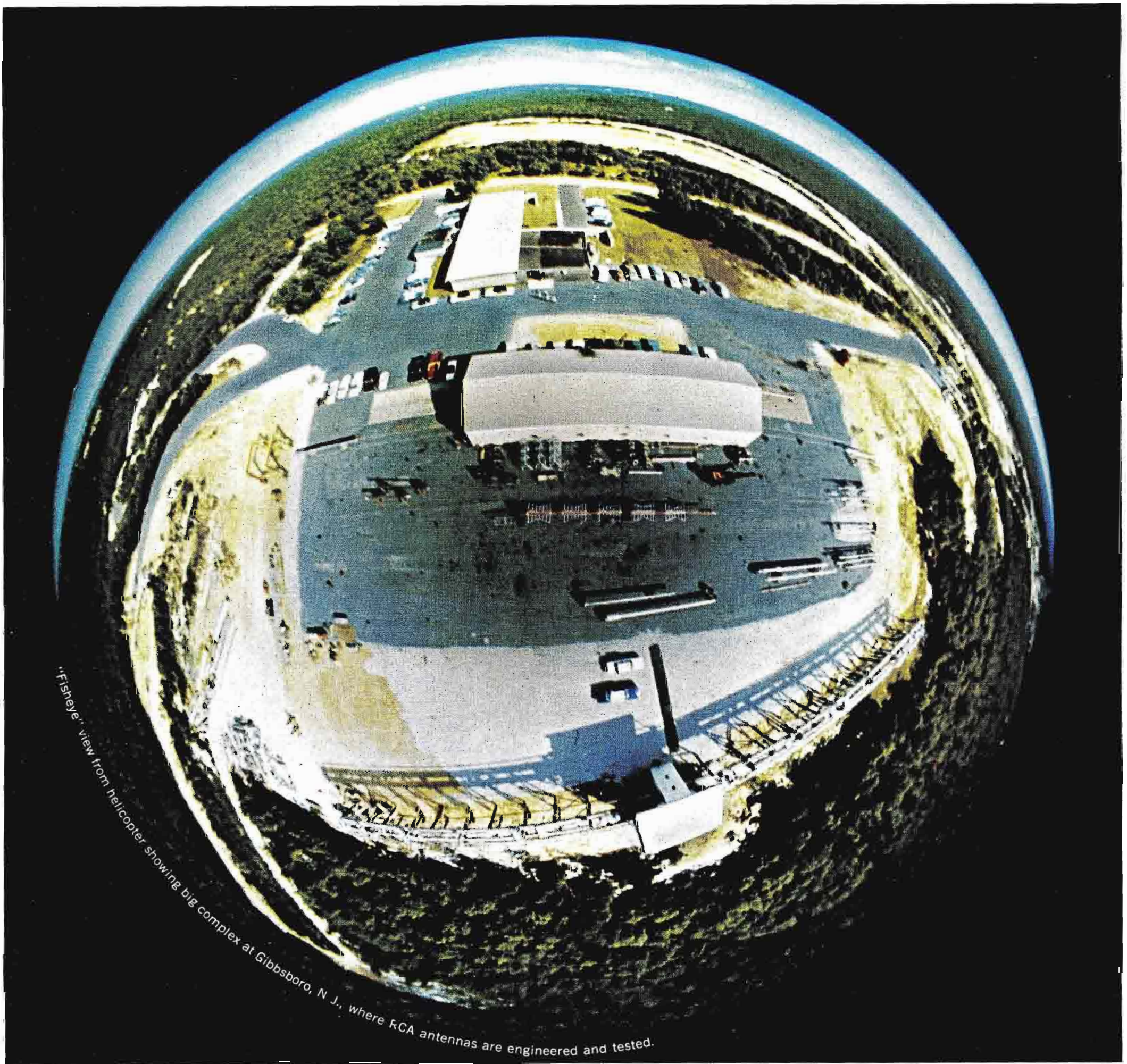

"Fisheye" view from helicopter showing big complex at Gibbsboro, N.J., where RCA antennas are engineered and tested.

RCA Gibbsboro...where most of the TV antennas come from.

A world of broadcast antenna engineering capability.

(1) Here, at Gibbsboro, is amassed a complex of RCA antenna engineering skills and facilities for design and production of radio and television antennas, filterplexers, accessories. Three large turntables handle full-size TV antennas for testing, while two small turntables handle model antennas. A stationary antenna trestle is large enough to accommodate four Traveling Wave antennas at a time. The main engineering office-laboratory and assembly buildings complete this facilities area. In addition—a test transmitter and tower for testing antennas transmit signals to the Gibbsboro complex from a site three miles away.



(6) The complex horizontal pattern of this UHF Panel antenna was tailored to avoid signal reflections from a mountain at the rear of the transmitting site, while meeting specific pattern requirements in three other directions. Each Zee-Panel radiating element is fully protected by its radome cover.

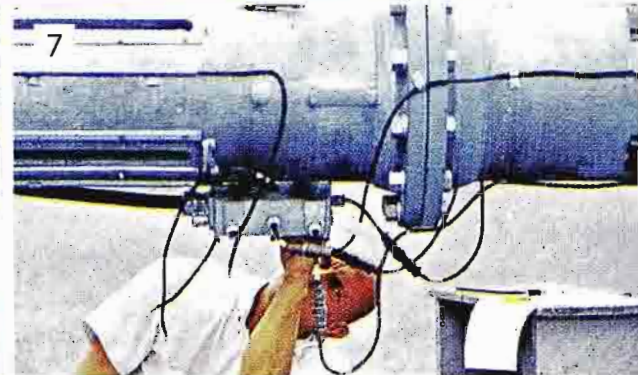

(7) Connecting the de-icer into the junction box on a TFU-45J UHF Pylon antenna. This is one of a new family of moderately priced UHF Pylons.



(8) Giant turntable called "Tiny Tim" where test antennas up to 15 tons move on a circular track 90 feet in diameter. It is one of three large turntables available for testing.

(2) Combined laboratory/office showing some of the engineering staff. Here is located the computer terminal where precise calculations assure an antenna with desired characteristics.

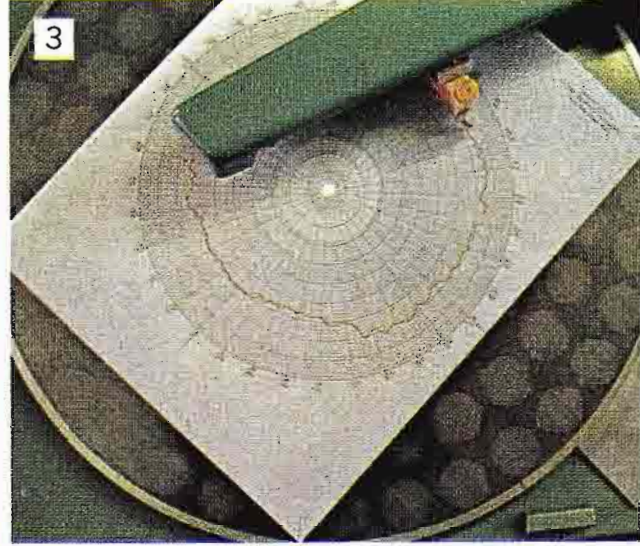

(3) Horizontal antenna plotter in use on one of the model ranges. New ideas for stacking and platforming were proved practical here. On this range, exact scale models of the Baltimore and Sacramento multiple antenna systems were measured to confirm mathematical studies.

(4) Huge stationary antenna testing trestle measuring nearly 400 feet in length. Phase and attenuation characteristics are measured in the three-story laboratory building which is flanked by two trestles. All the Traveling Wave Antennas now in use received their final testing here.



(5) Assembling one of the largest Pylon Antennas ever built. It will provide a base for a large Super Turnstile antenna in a stacked antenna arrangement.



(9) High-rise crane truck, shown conveying special UHF Panel antenna to testing site, is typical of many special equipments employed in this unique antenna engineering site. Pylons in foreground await shipment.

Widest choice from the broadest background in antennas.

No one has RCA's broad background of experience, nor the facilities to back up their experience in such a measure as RCA. And no one has produced as many TV antennas as RCA... Here's where the first Super-Turnstile—and all its famous offspring—came from! Here, too, are the engineering capabilities that produced the sophisticated VHF Traveling Wave antenna. Yes, and all the big multiple antenna systems—but one—came from

here. And for UHF, all the Pylons! It was here, too, that the ingenious design of the new Vee-Zee Panel antennas was first plotted and developed. And, of course, the new circularly polarized FM antenna also came from the drawing boards at Gibbsboro.

We hope you will visit Gibbsboro, and see for yourself how these antennas are engineered, how they are tested, and learn how they are followed up in the field

after they reach their destinations. After all, it's their actual record in the field that proves their superiority. As part of the RCA "Matched Line" they're all system engineered for finest performance with other RCA equipment. For more information, call your RCA Broadcast Representative. Or write RCA Broadcast and Television Equipment, Bldg. 15-5, Camden, N.J. 08102.

MULTIPLE ANTENNAS
Achieve optimum siting, minimum cost, choice of individual antennas.

VHF TRAVELING WAVE
For high band VHF, the finest antenna ever designed.

VHF OR UHF ZEE PANEL
Provides the widest choice of patterns. Shown radome enclosed.

UHF VEE-ZEE PANEL
Vertical panel antenna shown leg-mounted on triangular tower, leaving top free for other antennas. (UHF Pylon is shown on top.)

STACKED ANTENNAS
Combinations of Pylon-type-antennas with super turnstiles afford economies.

VHF SUPER TURNSTILE
This antenna has long been the standard of the industry. May be diplexed for use by two stations.

UHF PYLON
In use by the majority of today's UHF stations.

FM CIRCULARLY POLARIZED
Does the work of two antennas at lower cost, with less wind-loading.

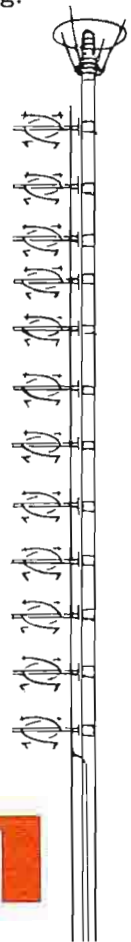
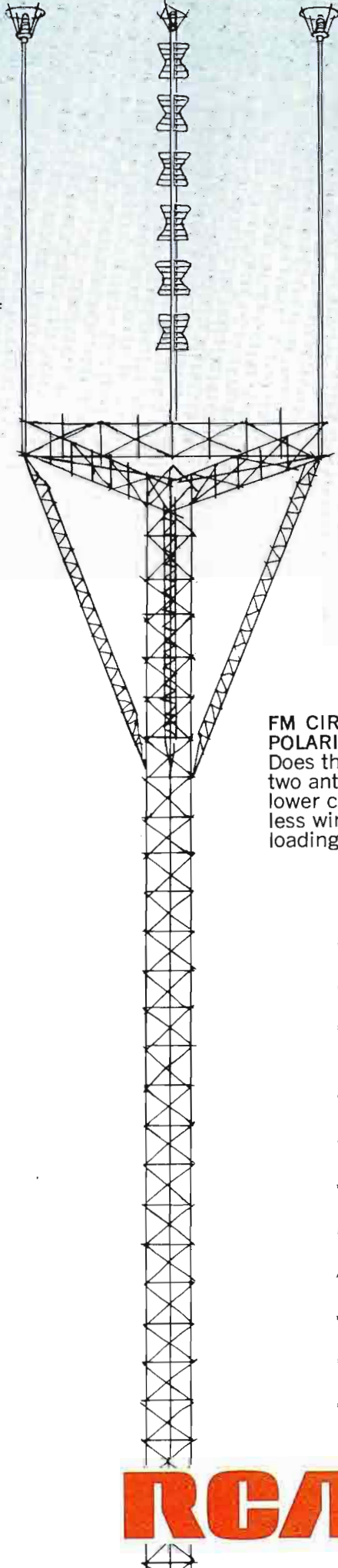
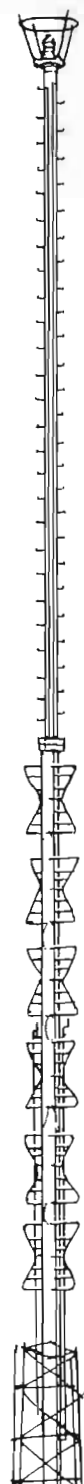
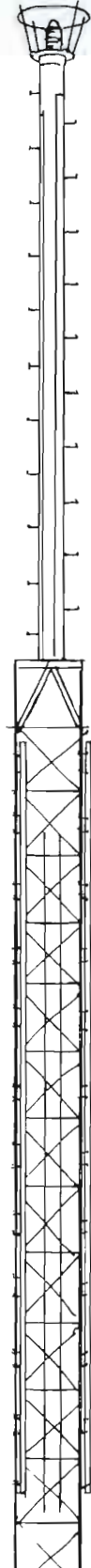
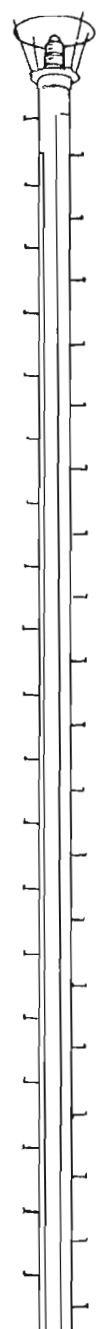
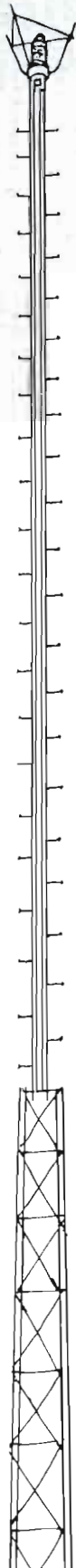
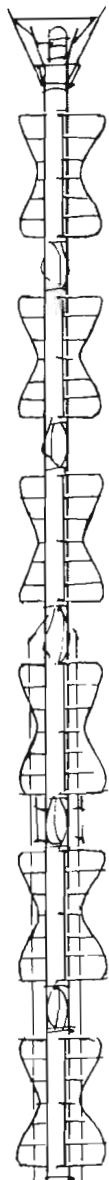

RCA

KHVH-TV LIVE PICKUP OF HAWAIIAN OPEN



Millions of viewers across Mainland USA saw “live” 2½ hours of golf when KHVH-TV color cameras helped capture the 1967 Hawaiian Open last November for the NBC telecast via Lana Bird II satellite.

The KHVH-TV color mobile unit was parked just off the 16th fairway, and the station’s three TK-42 cameras were placed to cover strategic shots of greens, fairways, and tees.

The RCA TK-42 color cameras “performed brilliantly” during the tournament, according to Lawrence S. Berger, general manager of the Honolulu station. One camera was located on a 10-ft. platform, the other two were on mobile hoists. KHVH had 23 people working at the tournament, both to operate their own equipment and to assist NBC.

To set the scene, the first shot to appear on the viewer’s television screen was the 17th green at the Waialae Country Club, with palm trees, the blue Pacific and magnificent Koko Crater and Koko Head in the background. Then the usual shots of drives, the recoveries from the rough, the blasts from the traps, and the close-ups of the putts. To make the

show sparkle with local color, there were cut-outs to views of Hawaii, from helicopter shots and film clips.

On the Mainland USA multiple millions saw “live” the one hour of golf on Saturday and 90 minutes on Sunday. In Hawaii, the show was seen over KHVH-TV at 1:30 p.m. Saturday and 1 p.m. Sunday.

As the last of the playing group left the 16th green, there were indications of a sudden death playoff which would follow immediately at the conclusion of the tournament and would start at the 15th tee. In order to cover this playoff, the KHVH crew moved the TK-42 that was covering the 16th fairway about 800 feet farther in order to cover the 15th green. The move was completed in 15 minutes. It was this camera that covered the deciding championship.

The signal was fed by the Hawaiian Telephone Company to Paumalu on Oahu, where an 85-foot dish beamed it to Lana Bird II—22,000 miles out in space, then back to earth at Brewster Flat, Washington. It was fed via microwave to San Francisco for retransmission to the NBC control room at Burbank, California, then out over the network.



WANT TO SHOOT THE MOON?

Here's How a Backyard Moon-Shot
Used the TK-43 Color Camera



FIG. 1 Moon-lit color exposure as cameraman follows the moon through haze on the horizon . . . preparatory to "Operation Moonshot".

FIG. 2 "Old Familiar Moon" presents test of TK-43 camera capabilities: resolution to capture surface detail and dynamic contrast range to faithfully portray the wide sweep of highlight to shadow. This unre-touched color photo from the monitor is the result.

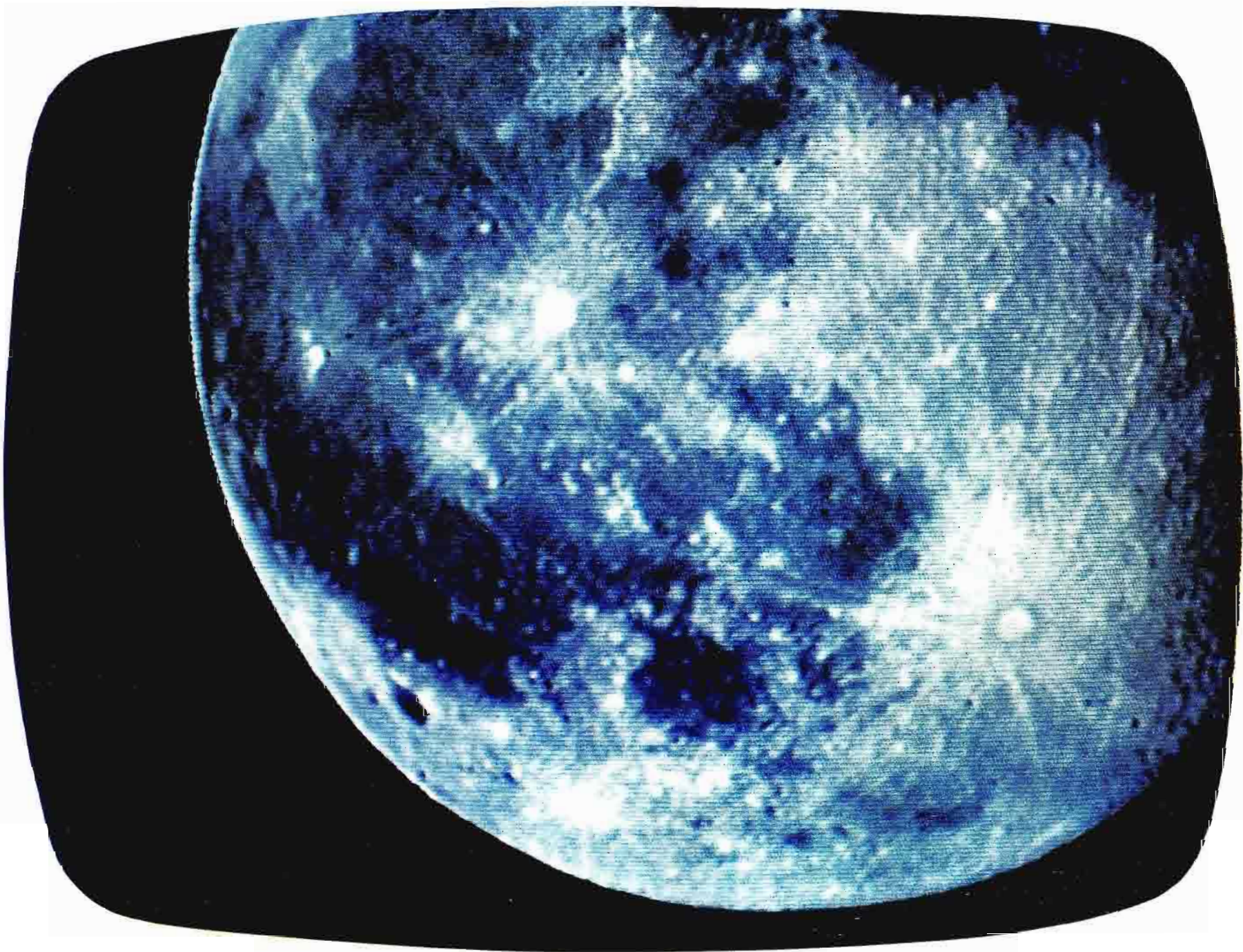

JEROME L. GREVER Manager, TV Camera Merchandising

Have you ever thought about televising the moon as an exciting visual aid to your news programs? The manned Apollo moon landing will be big news and deserves imaginative coverage. If you're an educator, would you be interested in televising the next eclipse of the moon? Intrigued with these thoughts, we discussed the possibilities. It was felt that, if realism were to be achieved, a moon pick-up would challenge camera performance—and would be especially demanding for a color camera.

Three major camera capabilities are important: resolution, to capture crater detail; sensitivity, because of the great loss of light with a telescopic lens; dynamic contrast range, so as to faithfully reproduce the tremendous range of highlight-to-shadow areas. Anxious to test the TK-43 under these conditions, we decided to take to the field for a look.

Old Familiar Moon

"I never noticed what the moon really looked like" was a typical comment of curious neighbors who gathered in the chill October air to watch our nine-to-midnight antics. A TK-43 camera with telescopic lens had been set up in the writer's backyard. Control equipment and color monitor were placed in the garage.

These people showed great interest in the moon's features—that old familiar moon which is often available for study with binocular or low power telescope. But most people don't take time to do that. And besides, with a television presentation they were able to point out specific features to each other. And what an unexpected surprise as the silhouette of a giant passenger jet crossed the moon on the screen. Because of these experiences, we believe television audiences

in general would be warmly responsive to timely telecasting of the moon. And it's easy to do—but more about that later.

Seas and Craters Pop Out

The moon pictures shown on these pages were all made using a standard TK-43 color camera with an astronomical telescope mounted in place of the usual zoom lens. A simple adjustable mount allowed the use of variable focal lengths which, for these shots, ranged from 85 to 125 inches. The photographs were made on $2\frac{1}{4} \times 2\frac{1}{4}$ " Ektachrome Daylight color film.

The moon shot shown in Fig. 4 was taken one night after full moon; therefore, a portion of the sphere is lost in shadow. The shadow (or terminator, as astronomers call it) moves from east to west. Prominent features of the moon, see Fig. 3, are easily distinguished.

Near the eastern limb, in the Sea of Fertility, the crater Langrenus and a chain of craters to the south are clearly visible. Grimaldi, near the western limb, is not a crater but a wall-surrounded plain or "sea." There is no water on the moon—the seas are actually dusty plains. Notice the great lunar crater Tycho, which radiates a mysterious system of rays and which has proved to be such an insoluble problem to the astronomer.

Simply sliding the telescope on its rod-type mount allowed us to go to a tighter shot, Fig. 5. Here the focal length was approximately 110 inches. The central peak of Langrenus can be detected in this photo.

Prominent is the great crater Copernicus. Astronomers hypothesize that the fine white rays emanating from Copernicus result from lunar particles and dust having been flung out in all directions when the crater was formed by the impact of a meteor. The brightest object on the moon's surface is Aristarchus, a high ringed plain or crater located westward from Copernicus.

Moon Landings

An interesting view of the "bottom" of the moon is shown in Fig. 2, focal length 125 inches. In January the U. S. moon-probe Surveyor 7 landed in the mountainous region 18 miles north of crater Tycho and is now sending back close-up pictures of the area. Northwest of Tycho, in the Sea of Clouds, Ranger 7 sent back the first close-up pictures of the moon in 1964. From this region radiates a curious system of light-colored rays or streaks. Their nature or origin is not known. Strangely, these streaks cross valleys, mountains, and craters with little change in appearance until they fade out with distance.

How We Did It

In order to get a good view of the rising moon, it was decided to do the pick-up in the writer's backyard (the roof of your station would do admirably). Some of the guys in the office "volunteered" to help. In case of rain, control equipment and color monitor were installed in the garage, with 200 feet of cable to the camera. The equipment was set up and checked

FIG. 3 Key features of the Moon. In-the-news seas and craters are identified in this drawing.

- SEAS**
- A CRISES
 - B FERTILITY
 - C SERENITY
 - D TRANQUILITY
 - E SHOWERS
 - F STORMS
 - G CLOUDS

- CRATERS**
- 1 ENDYMION
 - 2 LANGRENUS
 - 3 FURNERIUS
 - 4 TYCHO
 - 5 GRIMALDI
 - 6 ARISTARCHUS
 - 7 COPERNICUS

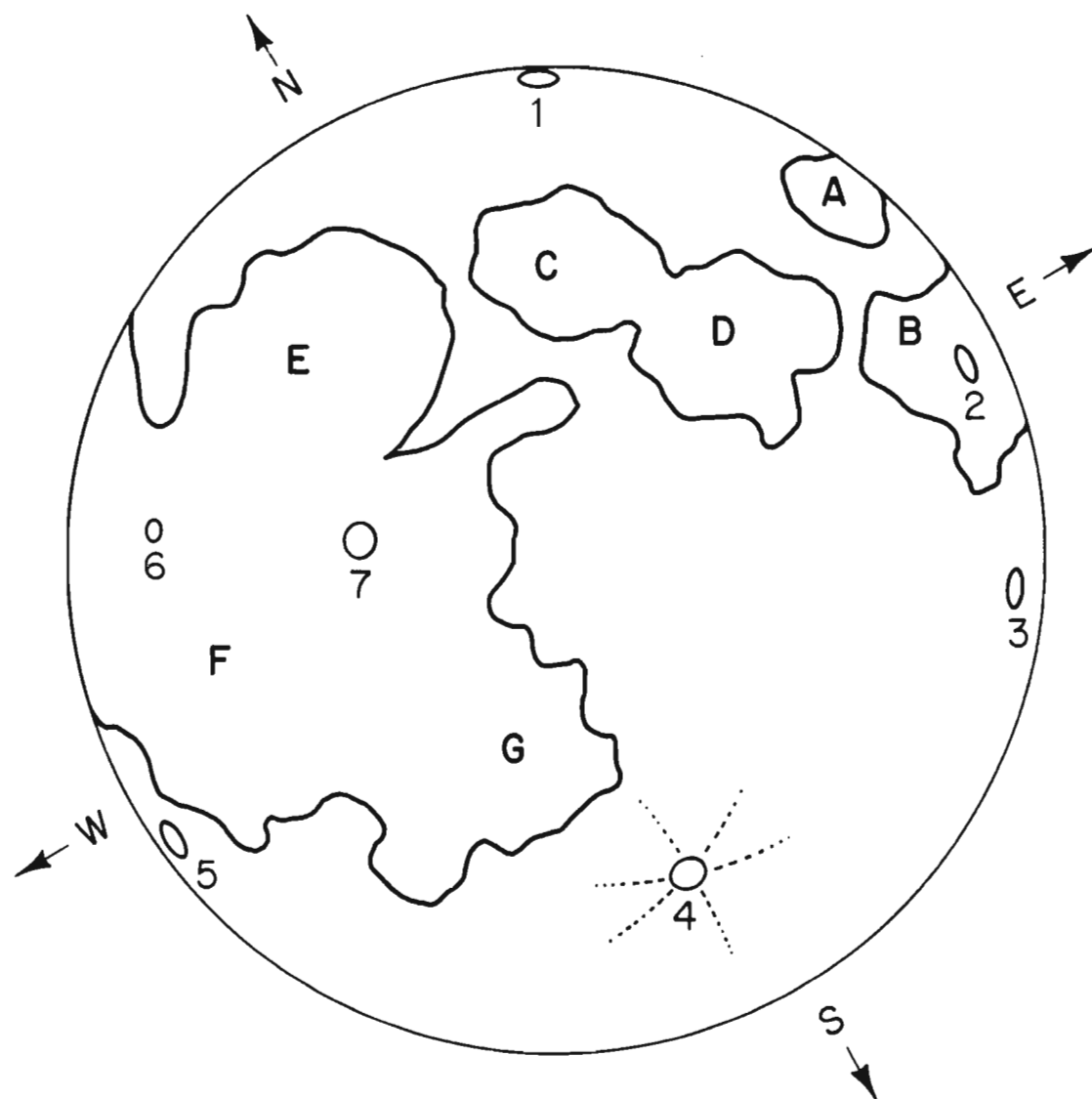

FIG. 4 Unretouched monitor photo of majestic ball in the sky. Television camera shows moon in proper orientation, not inverted as would be seen by telescope.



FIG. 5 A tighter shot with lens focal length of 110 inches. At this magnification, moon moved across kinescope at rate of 1 inch in 15 seconds.





FIG. 6 Mounting the telescope—a compact casegrain type which is readily adaptable to the TK-43.



FIG. 7 The camera was checked out early afternoon with the photo session scheduled for that same night.

out, all on the same day, with the photographic session scheduled for that night.

The camera was mounted on a field tripod and standard cam balanced pan/tilt head. We found that following the moon was fairly easy, but because of the long focal length it was difficult for the cameraman to avoid picture bounce. Aesthetically the most pleasing method of panning was to position the moon at the left of the raster and let it drift to the right, re-position and let drift. This gave a very real sense of motion as well as bounce-free pictures. And the motion was appreciable—the moon traveling across the kinescope at a rate of 1 inch every 15 seconds.

The only unforeseen difficulty was the problem of finding the moon in the viewfinder. The narrow lens angle made it difficult to rapidly locate the moon until the cameraman learned to sight along the upper edge of the camera body. It was in almost perfect collimation with the lens. A more elegant method would be to install a simple gunsight on top of the camera.

The only obstacle to successful moon televising seems to be the vagaries of weather and moon. In most localities, "seeing" conditions are poor until the moon rises quite high in the sky, above low-lying haze. Atmospheric conditions, such as very thin high altitude clouds can impair resolution and sensitivity. The phase of the moon is important. When the moon is full, its surface brightness is six times that of the quarter moon. Therefore, since f number is dependent upon lens magnification, much tighter shots can be taken when the moon is full or nearly so.

All moon photographs were taken off the kinescope of an RCA TM-21D color monitor. Color film used was Ektachrome Daylight, ASA speed 160, $2\frac{1}{4} \times 2\frac{1}{4}$ " format. Engravings reproduced here are made directly from the color transparencies with no retouching whatsoever.

The Telescope

For the telescope we used a small casegrain type made by the Questar Corporation. This lens is only 11

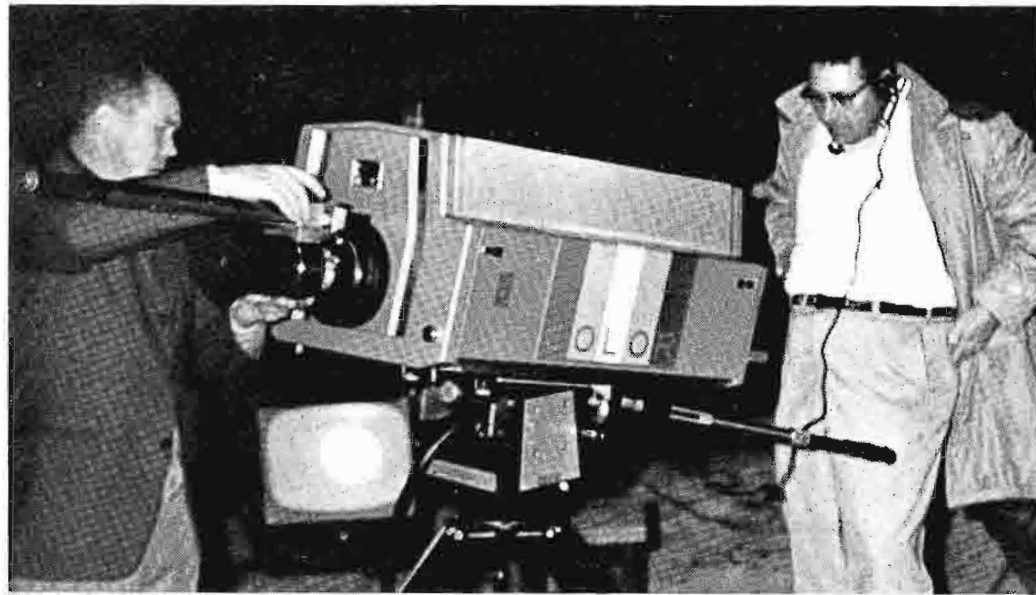

FIG. 8 The moon is up, and magnification of the telescope is set using monochrome picture monitor as a guide.



FIG. 10 Color monitor and camera control are set in the dimly lit garage where color photos were taken from the monitor.



FIG. 9 Closeup on the TK-43 as camera crew makes final adjustments before nightfall.



FIG. 11 Intercom at control position is used to keep cameraman alerted. Existing light exposures with forced development account for graininess in these black and white photos.

inches long by 4 inches in diameter and fits easily on the front of the TK-43. The telescope was supported by a 1-3/8" diameter aluminum tube which was affixed to the normal lens mount on the camera front casting. Thus, by sliding the telescope along the aluminum tube, any of a number of focal lengths could be chosen. We found the most useful range to be from 75 to 150 inches.

What Color Is The Moon?

Throughout art, literature and song, the moon has many colors. Ask three or four people what color the moon is and you may hear three or four different answers. Is the moon really silver or is it white? At dusk, it's not quite red, nor is it pink. In winter it seems to be whiter, or perhaps a pale blue. On a dry summer night the moon can be a dull bronze, its light filtered by scattered dust.

In our moonshot, color temperature of the monitor was approximately 9000° Kelvin. The color film used is balanced for a color temperature of 5500°, hence

the color photographs shown here exhibit a bluish appearance. As seen on the monitor, the televised picture was not blue, but rather had a monochrome appearance. It would seem desirable that, for an audience, a bit of color (take your pick) be painted in the picture using the "paint" knobs on the camera remote control panel.

In the News

This short experiment demonstrated to us the simplicity and practicality of shooting the moon with a TK-43 color camera. It offers interesting possibilities for use on news programs, live or from tape, whenever some new scientific development puts the moon in the limelight.

From the standpoint of educational broadcasts, other ideas come to mind; for use during an eclipse of the moon, or for study of the moon's changing features from new to full moon.

For your next special remote, look to the moon. It's there—and always interesting.

FIG. 1 A lady of the French Court in the CFTO color production of Henry V.

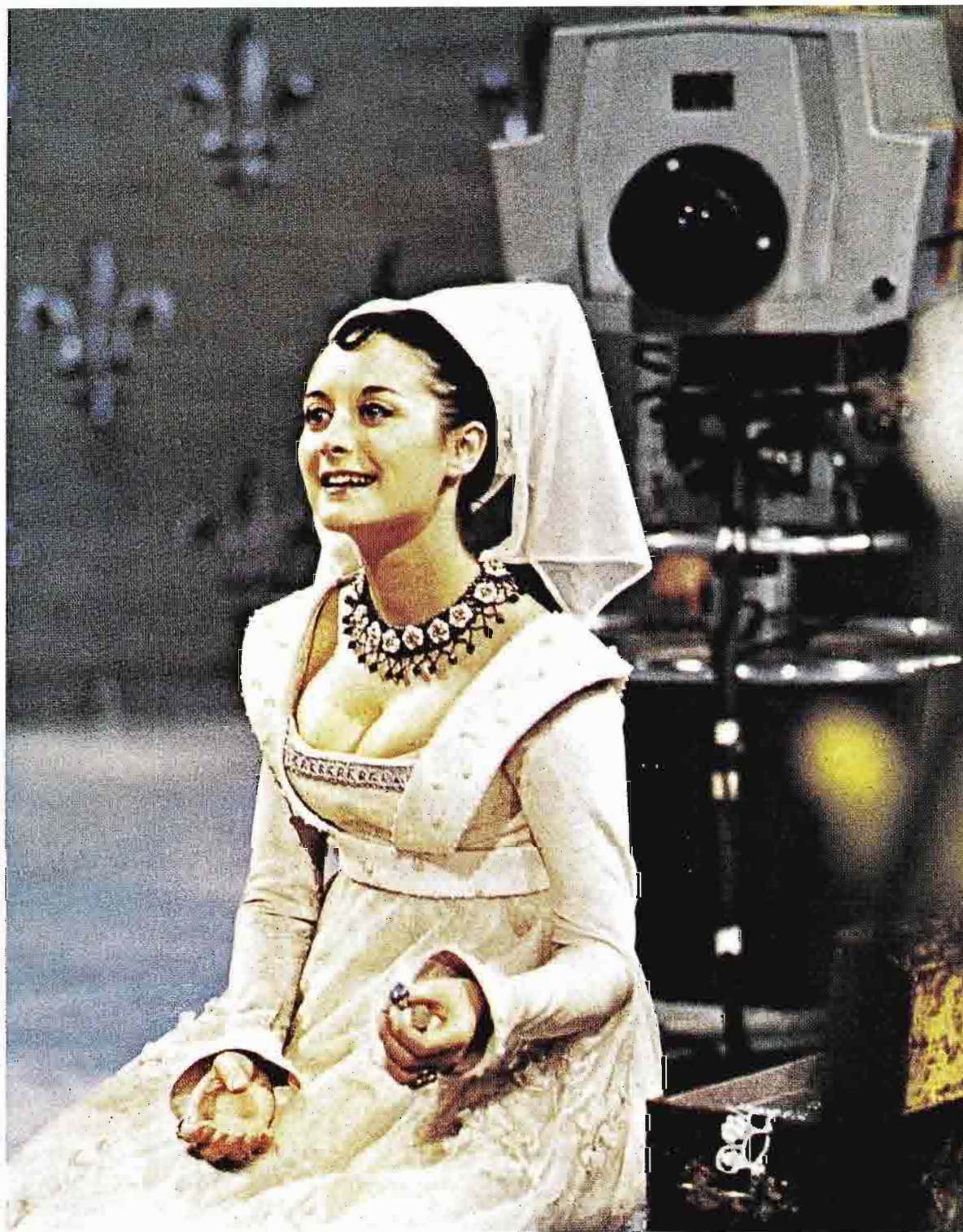

CFTO-TV SETS NEW STANDARDS FOR EXCELLENCE IN COLOR

Canadian Broadcaster and Producer Employs
11 BIG TUBE Cameras in 3 Mobile Units and
5 Studios to Produce a Host of Color Commercials,
Syndicated Shows, and Community Programs

When it went on air with independent CFTO-TV in 1961, the Baton Broadcasting Company had the dubious distinction of being the bottom-rated station in the Toronto-Buffalo-Hamilton area, but by 1967 the situation was dramatically reversed, in this golden triangle served by six stations—one independent and five networks. Furthermore, the services afforded by Baton Broadcasting has branched out into two other major avenues of operation: (1) Production Services—for producing national TV commercials for prominent advertisers; and (2) Glen-Warren Productions—for producing shows for syndication, in Canada, U.S.A., and worldwide, especially in color.

To what may this spectacular growth and extraordinary reversal be attributed? According to Mr. William Crampton, vice president and general manager of the station, there are two primary factors. Highest standards of excellence are sought—in personnel, equipment, and the TV picture. Perfectionism, fussiness, a tradition to make their machinery produce the finest—and it's reflected in everything they undertake.

Service to the surrounding megalopolis is a dominant factor. To excel in this aspect, educators are invited to produce programs using CFTO facilities. They are provided with a budget, a unit manager, a studio with full camera, staging and lighting, the technical crew,

and all required professionals. Toronto's symphony orchestra is presented regularly as part of the public service program, as well as the ballet and operas—without sponsors for the benefit of the community.

How it Started

When CFTO was designed and built in 1960, it was laid out as a color station, but because of the Canadian Government regulations, operated for the first five years solely in black and white.

Early in the summer of 1966, they installed two TK-41 color cameras and a TS-40 switcher, two TK-27

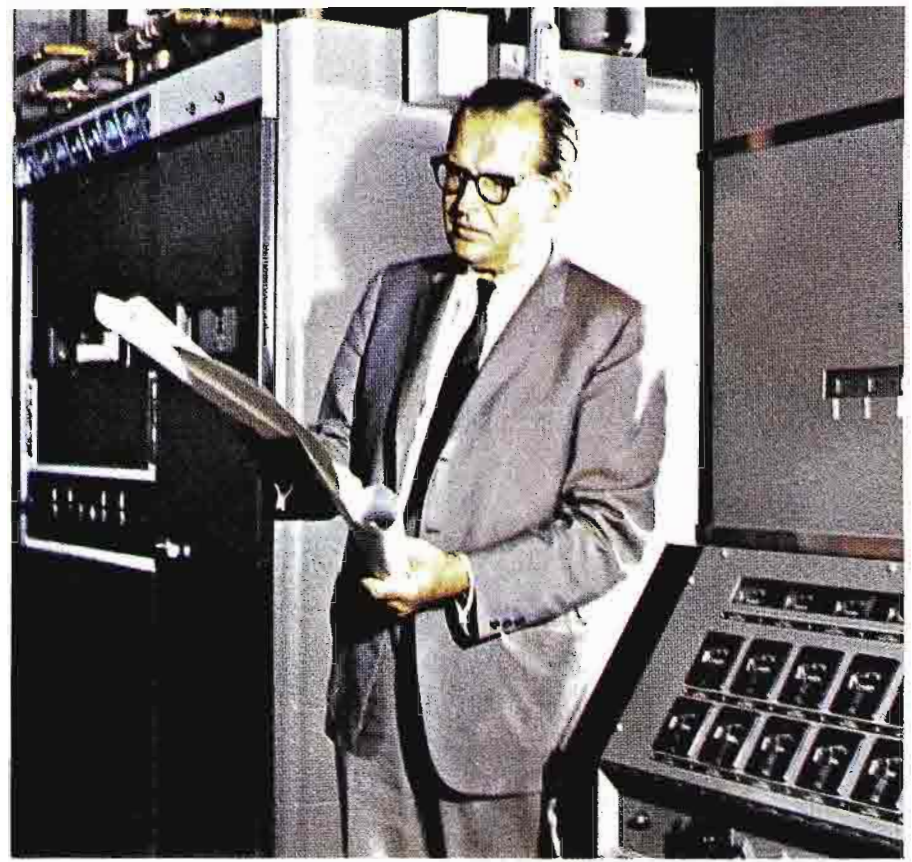
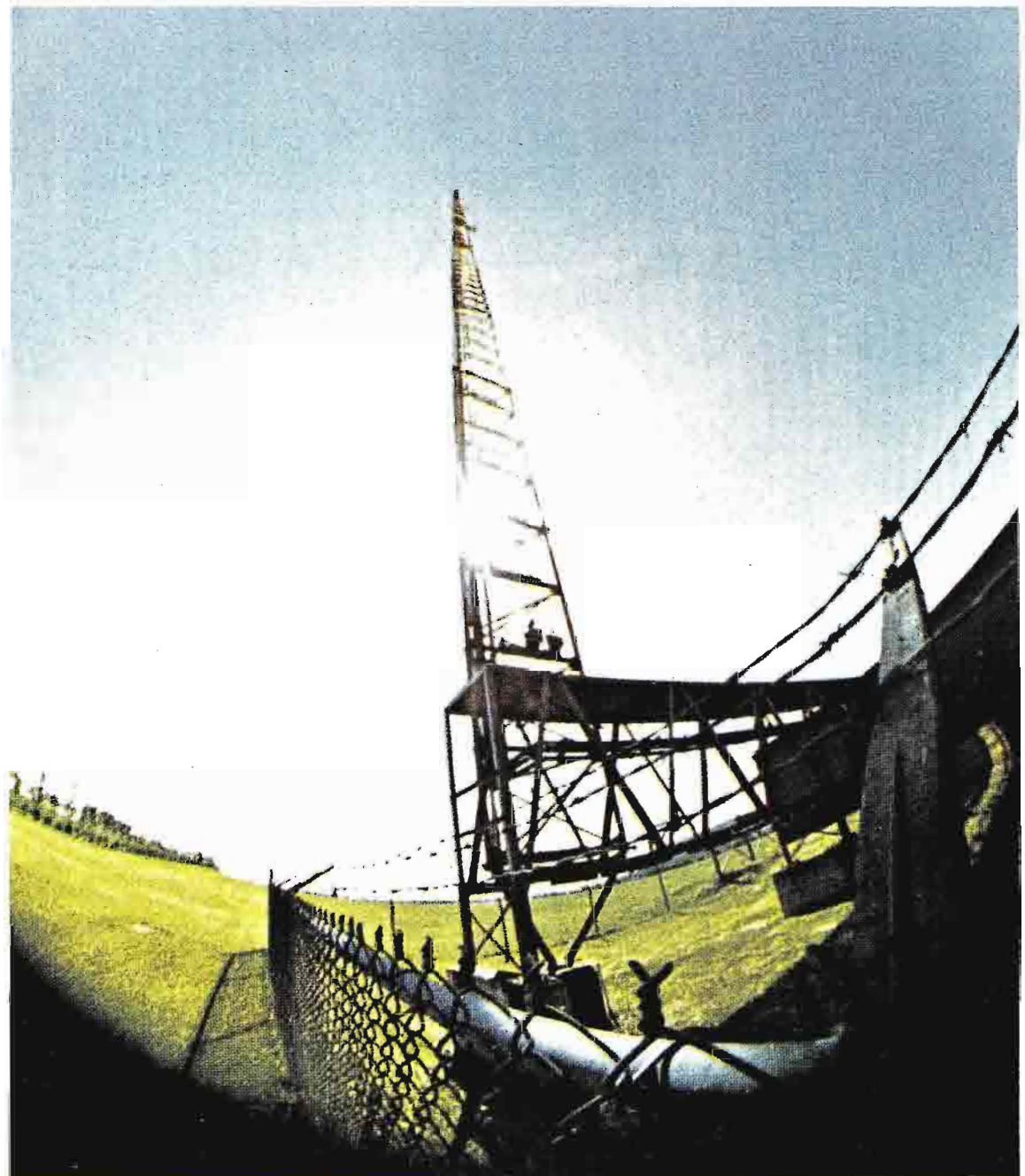

FIG. 3 Engineering Chief Helmut Berger reviews the transmitter layout with an eye to eventual expansion.



FIG. 2 Covering Tely Trophy Races at Mosport. CFTO covers in color, NHL Hockey, CFL Football, and League Soccer. Also specials like world water skiing, North American figure skating. CFTO color unit has travelled 50,000 miles in one year to cover sports.

FIG. 4 CFTO has first Canadian Traveling Wave Antenna atop a 900 ft. tower. It puts out a 325,000 watt signal.



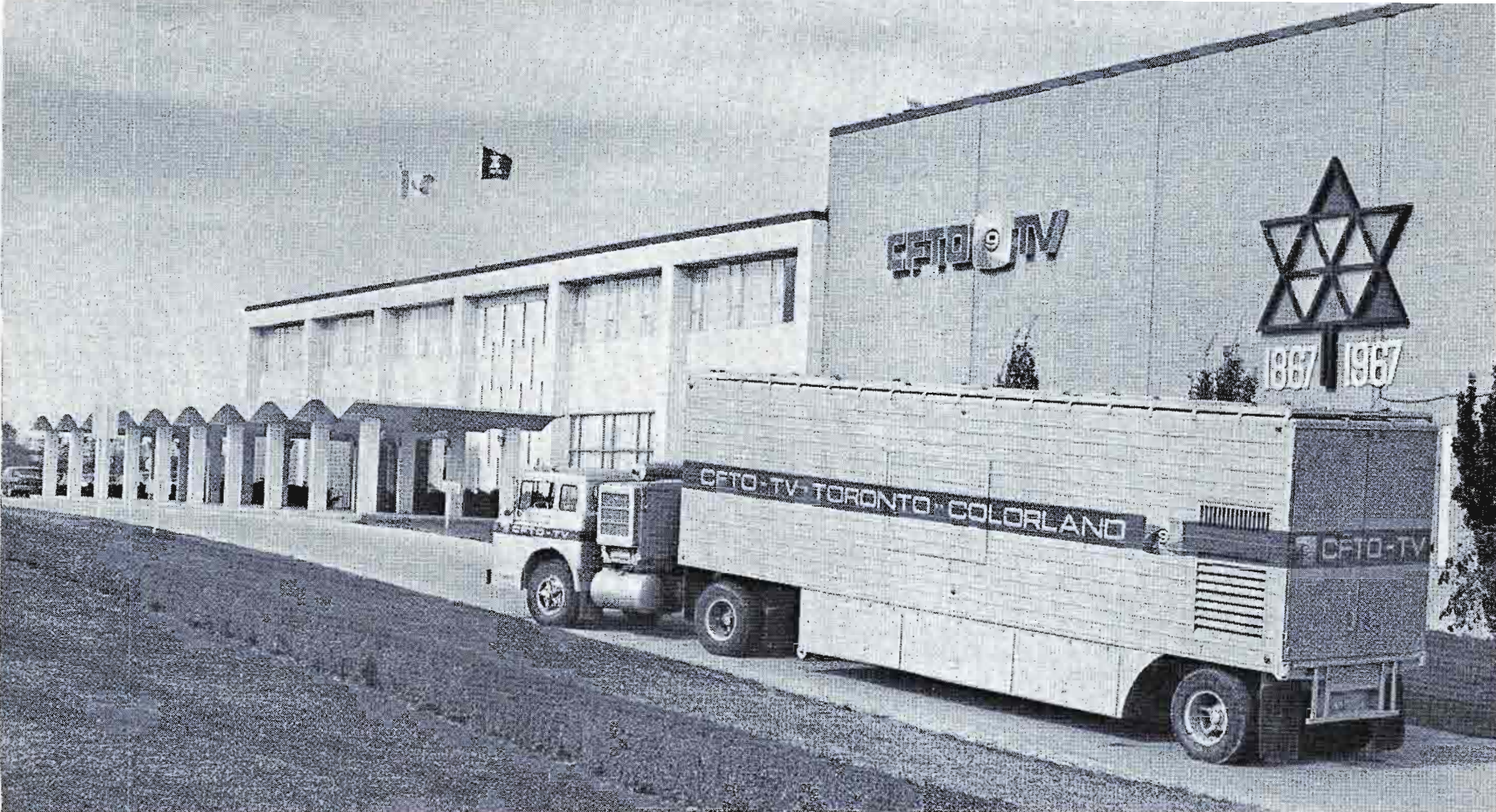

FIG. 5 CFTO-TV, Channel 9, Toronto is the largest independent color television station in North America.

color film systems, with TP-66 Film Projector and TP-7 Slide Projector, colorized the low-band and added two high-band VTR machines. In August, the first three of seven TK-42 color cameras were delivered together with CFTO'S first color mobile unit—ready for the Canadian Football League schedule. By January 1967, a second color mobile unit was added and the CFTO dream realized. It had become the largest independent color TV station in North America.

Growth of Color

Because of its early start and emphasis on quality, CFTO'S business demands became greater than anticipated. Affiliation with CTV required production of many color shows for the network. Color commercials such as Fyfe and Drum, Plymouth Fury, and Kraft Foods kept studios busy.

One year after official color in Canada, two more TK-43 color cameras were added, making a total of eleven, and a fifth color studio was equipped. A Production Services Company was organized to handle the volume of commercials and the Glen-Warren Productions launched to cope with the demand for Canadian produced color programs.

CFTO is located in metropolitan Toronto, population over 2 million. A 50KW RCA transmitter is used in conjunction with the first Canadian RCA Traveling Wave Antenna—for radiating 325KW from an 890 foot tower. In addition, a 2KW standby transmitter is available.

Color Central

CFTO faced the problem of maintaining consistent color quality. The fact that each person sees color

FIG. 6 CFTO travelled as far as the Bahamas to produce commercials for Timex watches.



FIG. 7 Production Manager Donald Davis (center) reviews expansion plans with technical staff so that changes coincide with needs of Production Department.





FIG. 8 CFTO employs the RCA Big-Tube matched color film system for all slide and film segments in their productions.

differently has always posed a problem. Further, color is graded by different station personnel from program to program, and day to day.

The solution lay in establishing color standards, then subjecting all color output to the color authority.

The staff designed and built a color control complex to provide ideal video monitoring of all color sources before they proceed to master control. This color central is independently located, apart from the studios and control rooms. It is designed exclusively for video; there is no audio monitoring.

The prime difficulty in standardizing on color quality can be overcome by reducing the number of people who pass judgment. In the CFTO concept only one man per 8-hr. shift performs this function. He is the senior video man, the one in charge of color central. He

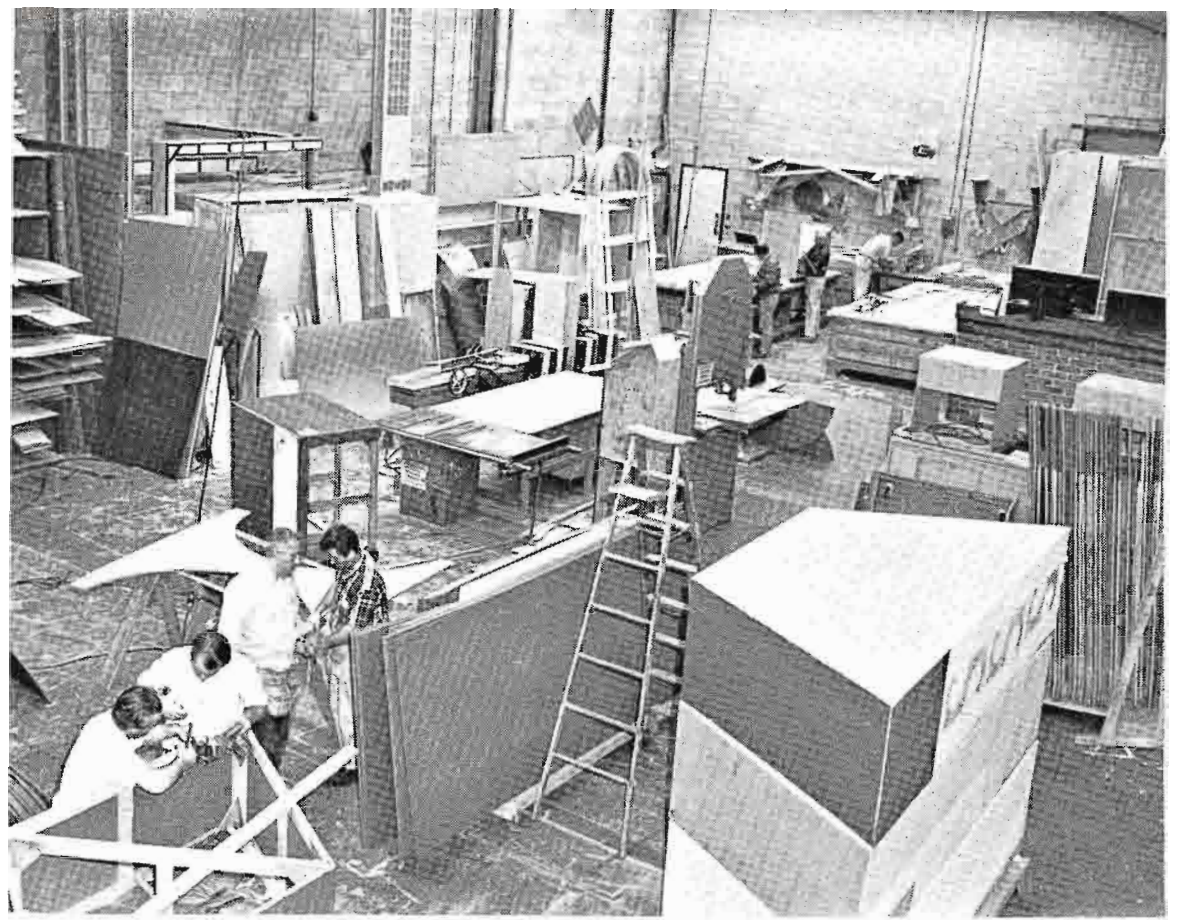

FIG. 9 An extensive in-plant facility is maintained for construction of studio sets and props.

has been especially selected after thorough testing of his color perception ability, and has received extensive training in order to qualify.

In this way all the programs and commercials to be aired or taped are color standardized. This careful procedure affords a consistently high level for all color output of the station.

Standards for Excellence

This filters from the top down. In explaining his reason for choice of color cameras for example, Mr. William Crampton, vice president and general manager, stated, "We need the best of color—something that will carry through 4 to 6 generations of TV Tape. Our large production of color commercials and syndicated color shows requires multiple generation copies. We

FIG. 10 Talent dressing rooms are adequate for handling the large productions of CFTO.





FIG. 11 Director Jack Lingeman adjusts settings for Kraft Commercials as Bruce Marsh reads through script. Hand models rehearse and dieticians prepare food for next commercial. CFTO has produced all Canadian Kraft commercials for three years.

cannot afford to compromise on the quality of color. We need the kind of resolution and definition that will carry through all copies."

This tradition is carried on in the words of Don Davis, Production Manager, "We have established the office of Color Coordinator in order to bring color quality up to the highest level and to maintain that kind of quality. As producer of commercials for top national accounts we are compelled to search for new ways to assure the ultimate in color. Our philosophy of the Color Central arises out of this need for perfection in color."

Engineering Director, Helmut Berger, expresses his view this way, "Our method for obtaining good color is not the same as others. We know the usual practice for a large broadcaster is to send many men to the RCA school for training color technicians. As a group these men exhibit a nominal amount of interest in the subject. We, however, deliberately send only two, or at the most, three men. We operate on the basis that these men will be our color experts. It is their job to teach others, and to establish and to maintain our color standards. As a result, our color men exhibit intense interest in the color training course and soak up just about everything that anyone has to offer."

CFTO has set up its own Color Standards Committee. Represented are engineering, production, and color coordination. This Committee sets the standards for, and the ways to control, color quality. By its very nature, the problem of production vs engineering is eliminated. While the Color Coordinator is at heart a production-minded man, nevertheless he must appreciate and appeal to both worlds.



FIG. 12 Mercury Cougar commercials are among many national accounts produced in color at CFTO.

PRODUCTION SERVICES

Several years after its inception, the services of CFTO-TV for the production of commercials was so much in demand that a separate organization was set up. This is Production Services, the commercial production division of Baton Broadcasting Ltd. It offers production facilities all under one roof, equipment rated as the finest on the continent, with creative talent and experienced personnel.

Soon after CFTO-TV procured its first RCA color camera, Production Services arranged a color seminar and demonstration of color TV techniques to advertisers and agencies. Invitations were extended to clients and to agencies to view their products and packages at a special color testing seminar held in CFTO-TV studios. The purpose of the session was to give advertisers an opportunity to evaluate their present pack-

FIG. 13 This commercial produced in color at CFTO won honorable mention from among 439 submissions in international category of American TV Commercials Festival.



FIG. 14 Actors in Henry V begin to set scene for battle that will follow in World's First Color Videotape of a Shakespearean play.



aging and production demonstrations, in order to determine their suitability for color television commercials. The product presentations were recorded on video tape, then played back for discussion and evaluation. In this three day seminar, agencies were exposed to the techniques for production of live action color tape commercials.

All the facilities of CFTO-TV are available for Production Services. Five studios equipped for color and monochrome, with TV film and video tape equipments are available for live and taped commercials. Two color mobile vans and one monochrome van are employed for on-location productions. Film productions are also handled—whether commercials, industrial or public relation films. Products cover a wide range: From automobiles to foods, and from appliances to newspapers—especially for national accounts.

G-W PRODUCTIONS

With the advent of color television in Canada, a

substantial upsurge took place at CFTO, especially for Canadian produced color programs. Foreseeing the future needs, a new Toronto company was set up to produce and to sell color programming to TV stations across the land.

Glen-Warren Productions, using the facilities of CFTO-TV, set its immediate sights on syndicated color TV for all Canada and ultimately to sell tape Canadian fare to U.S. and world television stations.

In June 1967, G-W Productions Ltd. announced the availability of its syndicated Sports, Musicals, Public Affairs and Children's Shows for color programming in the Fall.

Stations in the smaller markets, lacking the financial resources of stations in metropolitan markets, have difficulty finding Canadian-content programming that will satisfy the 55 percent ruling. Further, many cannot yet afford the not inconsiderable financial outlay for their own color programming but would be equipped to broadcast taped or filmed programs.

FIG. 15 Designed around a British Pub atmosphere with sing along and spontaneous entertainment, "Pig and Whistle" is color production, produced at CFTO.



Immediately available for syndication were four CFTO programs: Sports Hot Seat, Country Music Hall, Pig and Whistle, and Perry's Probe.

King Henry V in Color

This spectacular first in color television for Canada was undertaken by CFTO-TV using seven TK-42 cameras, its largest studio with a crew of 45, and a color mobile van, requiring 11 days for production. Presented was Michael Langham's production of *Henry V* by William Shakespeare. There was the same cast of 52 that plays at Stratford on Avon in Canada. It had been revised to two hours' playing time and was shown on the CTV network in January 1967 (will probably be seen again in 1968—also probably in the U.S.).

Executive Producer, Lorne Freed, explains, "When we wanted a subdued effect, we achieved it by lighting and by wardrobe selection, but most of all by the camera—we got the "Rembrandt" effect. There was a lot less work involved than we anticipated and, of course, we could always get vivid color, too.

"In the famous battle scene, we centered one camera and flew the cable so we could revolve it 360 degrees. In all, this camera turned around 18 times—of course, we would cut in with a few frames occasionally.

"We much prefer the type of color produced by the RCA camera. It doesn't make everything look like it's painted on a backdrop. The TK-42 gives depth to the scenes—one gets a three dimension effect."

Cameo sets for the different scenes were "interpretive" settings, simply built but effective in establishing mood and locale. Designed by Desmond Heeley, they were built at CFTO. John Cook, Canadian composer, created additional music for the TV production, which was added after the video tape was produced.

Rumble of Silence

This is another special, a movie length production of 90 minutes on tape and in color featuring an original Canadian prize-winning script. Three days were spent on location with the mobile van, two color cameras and high band color tape machine. Eighteen days were spent in the studio for rehearsals and shooting. A full day was spent for walk through, blocking, lighting—there were five full camera days. An original music score was used.

Producer and Director, Lorne Freed, stated that color matching becomes particularly important when shooting is done on different days and places. "We use a color girl for matching—each day we make a shot of the same girl against the same background with the same lighting—then check a playback on tape—before we proceed with the day's shooting.

"Our TK-42 and TK-43 cameras are very stable. This makes it easier to match color when editing—from one day to another—for example, orchestra close-up one day, audience the next day; studio shot one day, location shot the next."

Rumble of Silence was produced by CFTO and scheduled on the CTV network. It was seen across



FIG. 16 Executive Producer Lorne Freed discusses the action for a scene in "Rumble of Silence" with two of the performers.

Canada in small cities where stations do not have facilities for producing such specials and where people would not otherwise see such ambitious undertakings.

Venture in Color

In the beginning, CFTO was one of a total of 11 stations in Canada that built independent plants. According to Vice President Crampton, it was a "venture in faith." It was lavish—it was 30 acres, over 350 people, five studios, three mobile units, the largest color equipment order for an independent station. "It can't be done" was a common expression. Today, the studios are all working to capacity—there is so much demand for time on air that the station accepts only national advertising—and has the reputation for the finest in color.

FIG. 17 A night time on-location scene for "Rumble of Silence" in Toronto's unpredictable "village".



RACING IN THE RAIN TESTS TK-42 DOWN UNDER

It was raining at the Pakenham races. One of ATV-O's three black-and-white cameras had conked out. An RCA TK-42 color camera, at the station for evaluation, filled the gap and provided the first transmission of color television in Australia.

This initial color transmission was viewed by representatives of the Broadcasting Control Board, the staff of ATV, Channel 0, various members of the Australian press—and a few fortunate racegoers who

FIG. 1 Damp but undaunted camera and spectators follow the action of the steeplechase.



FIG. 2 ATVO engineers inspect the TK-42's "Big Tube".

lined up in rain outside the camera mobile unit to catch their first glimpse of color TV. The color portion of the races was relayed via microwave from Pakenham to the station headquarters in Nunawading, about 20 miles away.

And what was the result of all this color excitement down under? It is best told in the words of newsman Jim Keep as he described it in his story appearing in the AUSTRALASIAN POST:

An anxious television technician flicked a series of switches on a complex dial just after mid-day at a misty, rain-swept racecourse outside Melbourne recently. As he did it, he said: "It'll be a wonder if this comes off . . ."

He was giving the history-making "go" signal for Australia's first "live" transmission of color television. This happened at Pakenham races, 20 miles away from the ATVO studios, at Nunawading.

Weather conditions had cast a gloom over everybody concerned with the test project.

We were sitting with the technician, RCA Field Engineer Ray Sheldrick, inside a giant Outside Broadcast van near the saddling enclosure, waiting for a color picture to flash on a 21-inch monitor screen in front of us.

In the murk outside, cameraman Colin Mitchell panned the studio's new American color TV camera to a woman admiring some artificial flowers ("planted" specially for the occasion) and hoped for the best.

The picture that emerged on the monitor screen set Ray Sheldrick shouting with excitement, "We've done it! It was a long shot on a day like this, but we've done it. You beauty!"

The screen was a blaze of colors, each one blending perfectly. With the aid of a technician's tuning know-how it gave the impression that the weather was indeed fine!

Royal Ascot couldn't have looked gayer that Pakenham on the color screen.

Back at the ATV studios, where the color image was being received on a closed circuit link, visiting overseas TV experts were amazed by the "bang on" reception.



An American RCA technician told us later, "It's as good as anything we see in the U.S."

Away from the racecourse and the studios thousands of Victorians were watching the same picture in black-and-white.

When a monochrome camera at the course suddenly developed technical problems, the color camera — an RCA TK-42 that had arrived in Melbourne only a few days previously — was allowed to show its versatility.

A four-in-one camera, equipped with three color tubes and also a black-and-white tube, it televised the races in both forms without a hitch.

We watched BOTH color and black-and-white on twin monitor sets in the O-B van, and no doubt remains about which is the more exciting viewing.

Color won in a canter. Jockeys' colors and the horses; blacks, greys, chestnuts and browns, flying down an incredibly green stretch of turf was in sharp contrast to the same scene in black-and-white.

Well-known racecaller Bert Bryant is sold on color and its possibilities. In his opinion, the day may come when it will be possible to broadcast a race sitting in the studio—from a monitor set!

He said, "It could lead to far greater accuracy because the colors are brighter and sharper. A broadcaster relies almost entirely on jockeys' silks and horses' colors, and this form of television could help him tremendously."

The Pakenham evaluation came on the heels of the TK-42's closed-circuit debut in Sydney. The camera was demonstrated as part of the week-long National Convention of the Institute of Radio and Electronics Engineers.



FIG. 3 A quick checkout with the cameraman, and the TK-42 is "race ready".

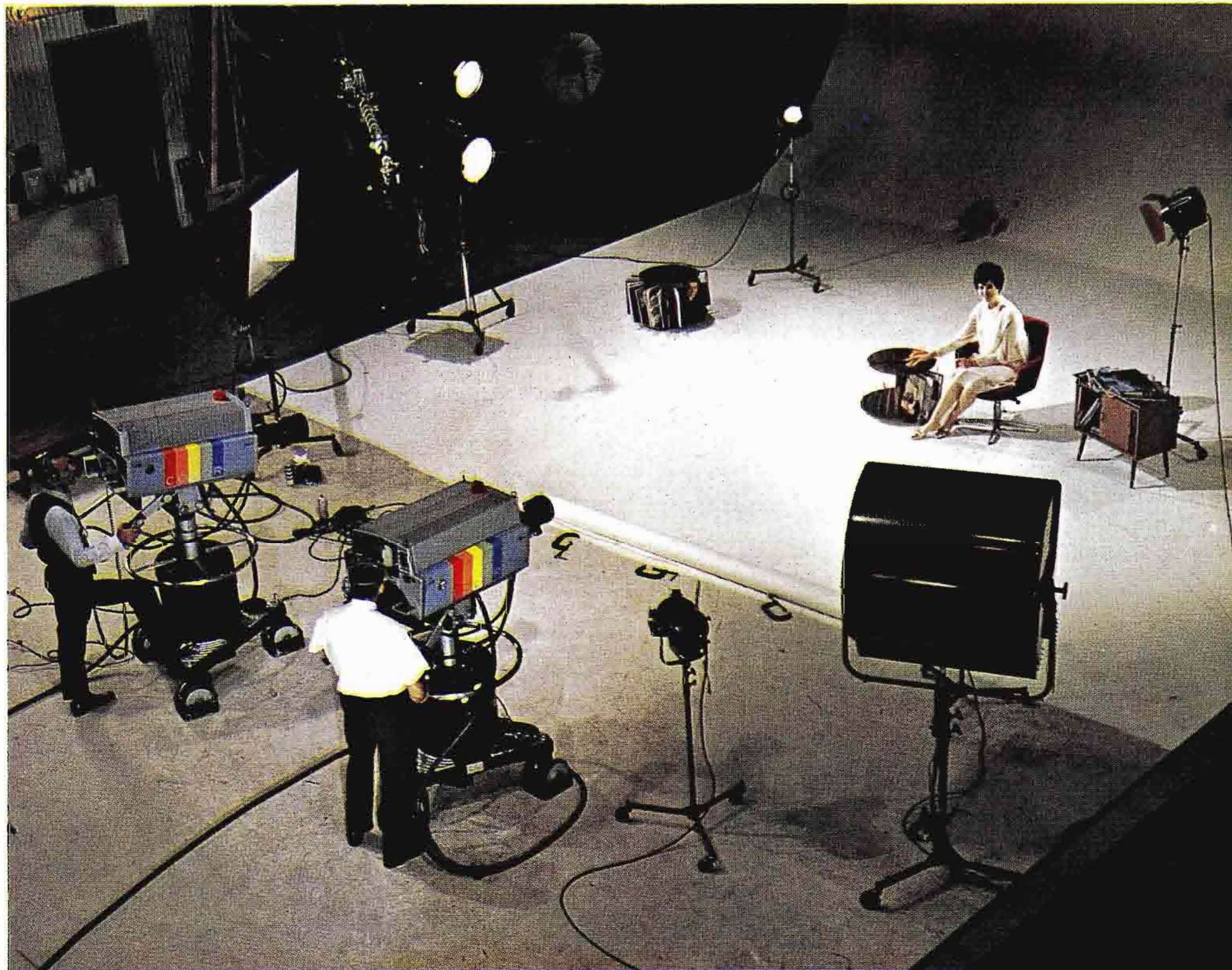

The sweep of the RCA TK-43 color cameras on this large set for a furniture commercial brings out every selling nuance in the scene. "How the *Record-Go-Round* replaces old-fashioned clutter" is a story well told.

We put a kick in our commercials with RCA TK-43's! . . . Pictures are the sharpest, colors more vivid, skin tones most natural.

With two mobile units and four TK-43 color cameras always ready to take off to points unknown at a moment's notice, LewRon Television, Inc. makes quality with mobility the keynote of their color television production service. In their own words they "do anything, go anywhere, with the finest of studio equipment."

The two vans house the complete production system—cameras, control, switching, monitoring and taping. Their RCA color cameras produce the finest studio quality pictures, under all conditions—whether on location in hot sands of California or in air-conditioned studios of the East.

"The RCA TK-43 color cameras provide the kind of pictures that sell on sight," says Ron Spangler, president of LewRon. "Once we get oriented on a job, we know it will be a success . . . colors are more vivid . . . skin tones are the way skin really looks . . . pictures consistently sharp. Our clients like the believability and freshness these cameras give their commercials."

You don't have to go as far as LewRon goes to prove the superiority of RCA color cameras! Ask your Broadcast Representative to fill you in on other users. Or write RCA Broadcast and Television Equipment, Building 15-5, Camden, N.J. 08102.



The "magical disappearances of King Syrup at the breakfast table" is faithfully depicted by the TK-43 cameras. Only the hands and the product are seen in the finished commercial, so natural colors—from fingers to golden brown syrup—are a must.

Remote color pickups on tape—commercials, sports events and local performances of any type are handled from this color control center.

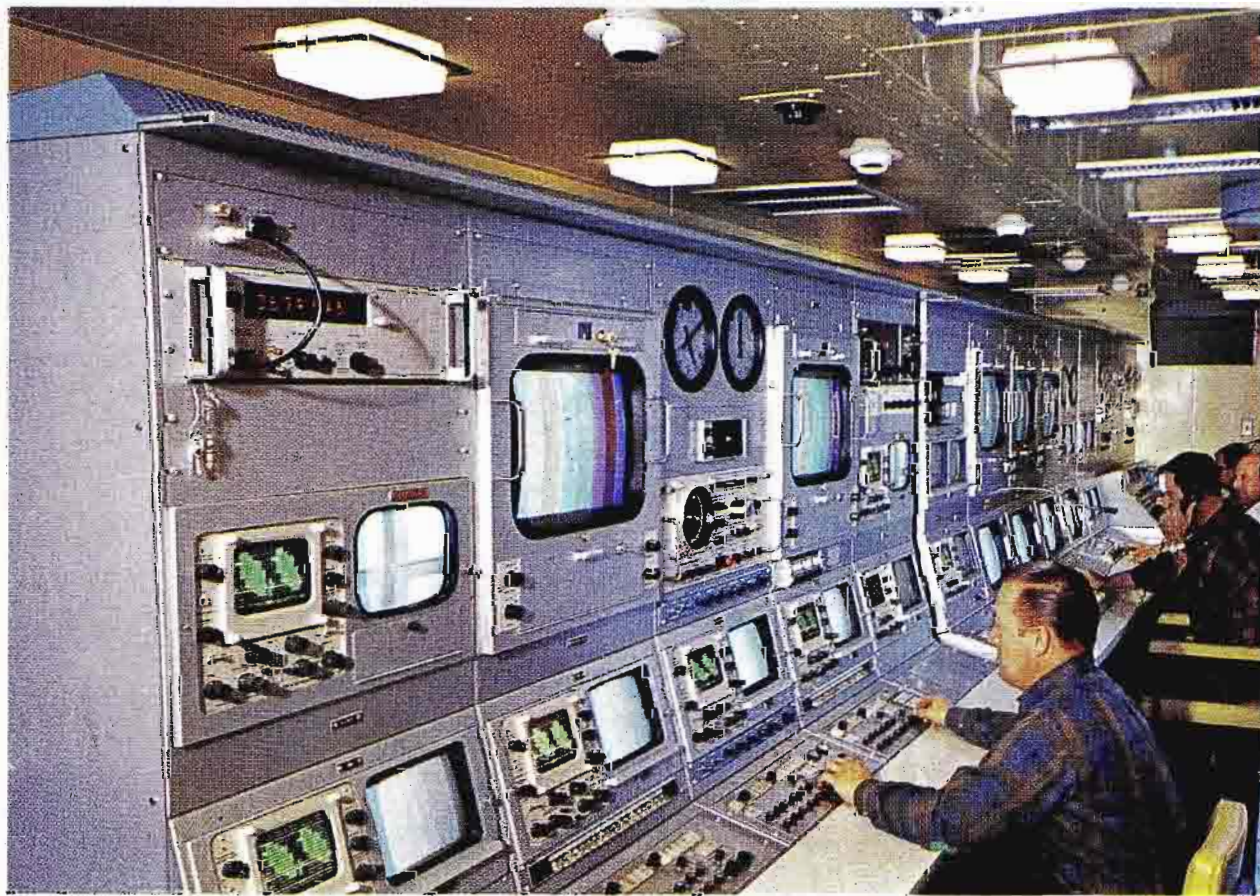

The two big mobile television vans which LewRon provides for on-location commercials contain a complete production facility.



Return-Beam Vidicon System Achieves 5000 TV Lines Resolution

Produces Pictures Ten Times Sharper
Than Conventional TV Images
For Observation Via Satellite

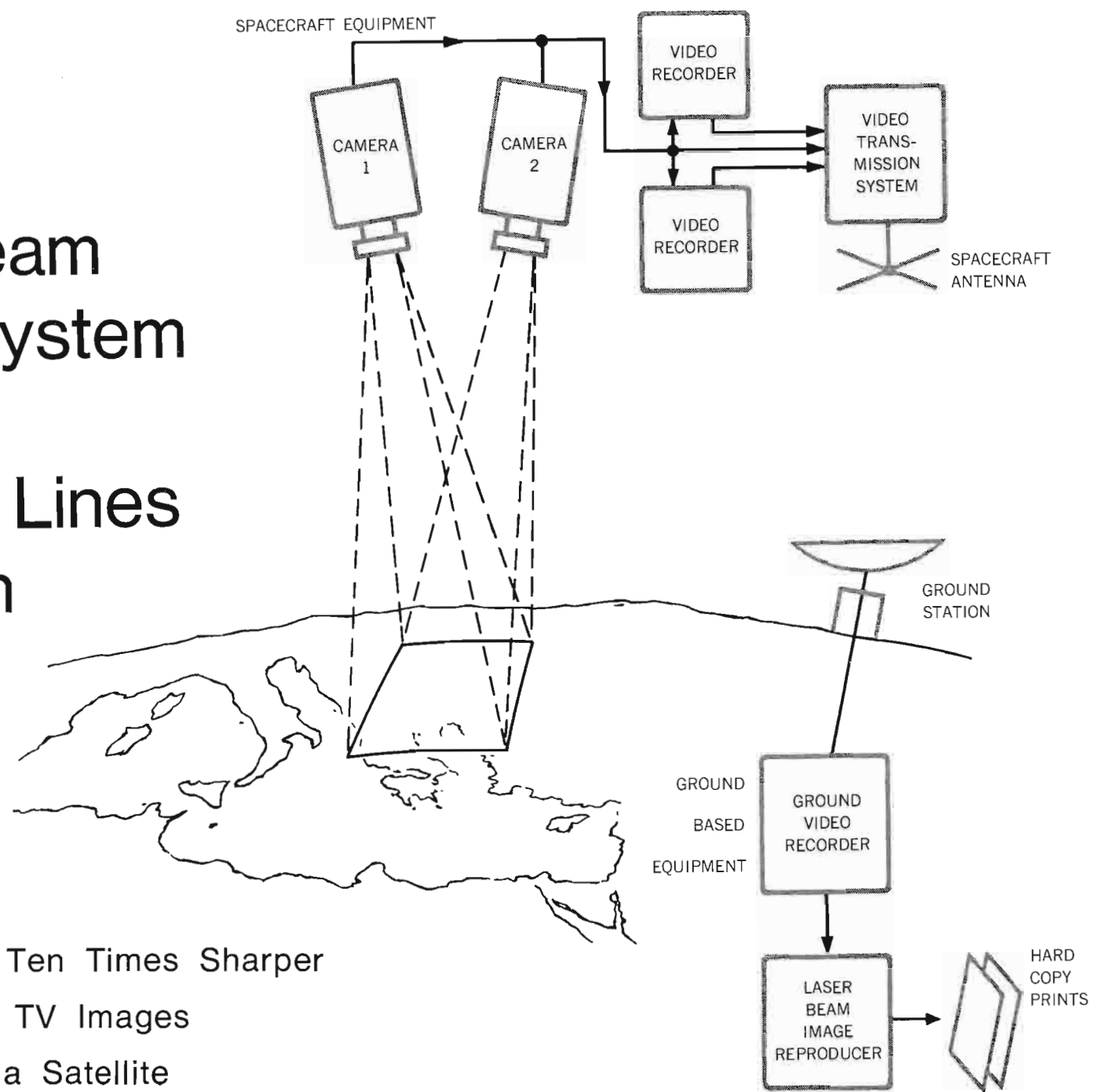

The union of television and laser technology results in high resolution photographs of the earth and the planets. The system makes use of a new TV camera tube that sends its pictures to a gas laser, whose beam retraces them on film at a rate of 1200 lines per second. Although designed primarily for use in an earth resources observation satellite (EROS), possible industrial uses include microcircuit manufacture, news photo transmission, and graphic arts production.

The camera system, developed by a team of engineers at the RCA Astro-Electronics Division, Princeton, N. J., is capable of 5000 TV lines resolution. This high resolution is made possible by a "return beam vidicon" developed by Dr. Otto H. Schade, of RCA Electronic Components.

FIG. 1 New laser beam image reproducer is demonstrated by RCA engineer Dennis Woywood. The unit is recording by laser beam an image consisting of 5,000 TV lines on a 9 x 9-inch photograph plate. Such images are transmitted to the laser by a new "return beam vidicon" TV camera, shown in background, that produces pictures 10 times sharper than those provided by a standard TV camera.



FIG. 2 This print of the Salton Sea was reproduced by a TV imaging system typical of those presently used in space. Resolution is approximately 800 TV lines.

In operation, a "laser beam image reproducer" converts the vidicon signals to a picture by scanning photographic film with a narrow beam of laser light. The reproducer was developed by a team of engineers in the Camden RCA Advanced Development section.

Return Beam Vidicon

The RBV is a magnetically deflected, magnetically focused vidicon imaging device with a two-inch diameter faceplate. It operates as a vidicon in that a photoconductor is charged by light and discharged by a scanning beam. It differs from normal vidicon operation in that the return beam is utilized as a signal path similar to the operation of an image orthicon. The RBV provides high resolution with a theoretical limit of 8000 TV lines, high signal-to-noise ratio, excellent low-light sensitivity and high image retention. These features make it ideal for use in a satellite designed to acquire detailed information for mapping, agriculture, forestry, exploration of new mineral resources and similar activities.

General characteristics of the Two-Inch Return Beam Vidicon as it is presently conceived for an earth resources satellite are:

Resolution and Bandwidth

System Resolution5000 TV lines, with near term potential for expansion of 50% or more

FIG. 3 This print of the Salton Sea was reproduced by the RCA Two-Inch Return Beam Vidicon-Laser Beam Image Reproducer. Resolution is in the order of 5000 TV lines.



System Resolution referred to Sensor	100 line pairs/mm
Number of Scan Lines	6000
Scan Rate	1200 lines per second
Readout Time	5 seconds
Video Bandwidth	4.0 MHz
<i>Dynamic Range</i>	
Sensor Dynamic Range	100:1
Signal-to-Noise Ratio (p-p/rms)	40 dB
<i>Exposure</i>	
Highlight Exposure	0.01 foot-candle-second
Exposure Time	1.5 milliseconds

The RBV photoconductor target is similar to that of a conventional vidicon. The exposed photoconductor is scanned by a low-velocity beam produced by an electron gun consisting of a thermionic cathode, a control grid and an accelerating grid. The electron beam is focused at the target by the axial magnetic field of an external focusing coil and the electrostatic field of another grid. The shape of the decelerating field is adjusted by a grid to obtain uniform landing of the electrons over the entire target area. Alignment of the beam on the target is accomplished by a transverse magnetic field produced by an external coil located at the base of the vidicon. Deflection of the beam is accomplished by transverse magnetic fields produced by external deflection coils.

The electrons turned back at the target form the return beam which has been amplitude modulated by absorption of electrons at the target in accordance with the charge pattern whose more positively charged areas correspond to the highlights of the TV scene.

The complete electron round trip occurs in significantly less time than it takes for the deflection field to laterally displace the beam. The return beam is directed to the first dynode of a five-stage, electrostatically focused electron multiplier which amplifies the modulated beam current.

The gain of the electron multiplier produces an output signal level sufficiently above the noise level of the video signal. The signal-to-noise ratio of the video signal, therefore, is primarily determined by the shot noise from the modulated electron beam. The video signal is amplified through the appropriate bandwidth video amplifier and then into aperture-correction circuits.

Camera Electronics

The camera head consists of the camera mount plus an optical system which may vary depending on the goals assigned to a mission utilizing the new Vidicon.

Most of the electronic circuitry required to operate the Return Beam Vidicon is located in the electronics package. This unit contains the power supply, regulator circuits, deflection circuits, and video amplifier circuits. All electronic circuits shown in the accompanying block diagram have flight qualified on either the Nimbus or TIROS/TOS programs, and are proven high-reliability designs.

Operational Characteristics

The RCA Two-Inch Return Beam Vidicon's extremely high resolution is made possible by slow scan operation and return beam operation.

It has been shown that the size of the scanning beam in a vidicon is directly proportional to the beam current. As the scan rate is decreased, the beam current may be decreased to maintain a constant number of electrons landing on a unit area of the photoconductor. Thus, a smaller spot size and higher resolution are obtained at slow scan rates.

By utilizing the return beam as the signal path, electron multipliers may be employed to amplify the signal, resulting in greater sensitivity of the device. Therefore, the RBV requires much less incident illumination on the photoconductor than the normal vidicon. Thus, the beam current may be further reduced, resulting in improved resolution.

Picture Taking Cycle

Operation of the RBV as it is envisioned for an earth resources satellite involves three basic operations: prepare, expose, readout. These occur over 20 seconds.

Prepare (0-12.5 seconds): The first 200 milliseconds of the prepare sequence are used for erasing any residual image on the vidicon photoconductor. This is accomplished by energizing a set of four small tung-

sten flood lamps located around the RBV faceplate that illuminate and completely discharge the photoconductor. After erasure, the photoconductor is prepared for exposure by charging the surface uniformly to the cathode potential. The preparation operation consists of scanning the vidicon target five times at twice the normal scan and frame rates, which requires 12.5 seconds.

Expose (12.5-15 seconds): During the expose period of the picture-taking cycle, the RBV electron gun is biased off, and the target voltage is changed to its readout potential. After 1.3 seconds (13.8 seconds elapsed cycle time) the photoconductor is optically exposed to the scene image for a period varying between 0.5 and 2.0 milliseconds. Five exposure times varying by factors of $\sqrt{2}$ are available in this range.

Readout (15-20 seconds): In the readout sequence, the electron gun of RBV is turned on, and the photoconductor is read out. The readout scan rate is 1200 Hz, and the readout process is completed in five seconds, giving a total of 6000 scan lines.

Readout time and vertical resolution: There is an optimum "develop" time associated with the vidicon photoconductor that results in the best sensitivity and resolution. Because of this, a delay time is introduced between the time the photoconductor is exposed to light and the time readout is initiated. For the ASOS photoconductor, this delay has been found to be 1.2 seconds. Sensitivity and resolution have been found to be a function of readout time of the full picture. The best resolution occurs when the photoconductor is read out for 5 seconds beginning 1.2 seconds after exposure.

Data Transmission and Reproduction

The images recorded by the Two-Inch Return Beam Vidicon can be stored on tape either aboard a satellite for later transmission to a ground station or can be transmitted directly to the ground station, where they can be recorded on magnetic tape or film or both simultaneously.

Because of the high resolution offered by the RBV, RCA has developed a revolutionary Laser Beam Image Reproducer (LBIR) to reproduce RBV images with minimum degradation. The LBIR utilizes a laser beam to deposit the images on conventional photographic film.

The Laser Beam Image Recorder

The Laser Beam Image Recorder uses coherent optical techniques to produce a modulated rapidly scanning, recording spot of light. This recording spot of light produces a permanent record of processed input signals on conventional silver halide photographic film.

The major functions of the Laser Beam Image Recorder are: 1) establishment of basic recording energy source; 2) modulation of energy source by signals to be recorded; 3) focusing of modulated energy source into a high energy density recording spot; 4) scanning of recording medium by this recording spot.

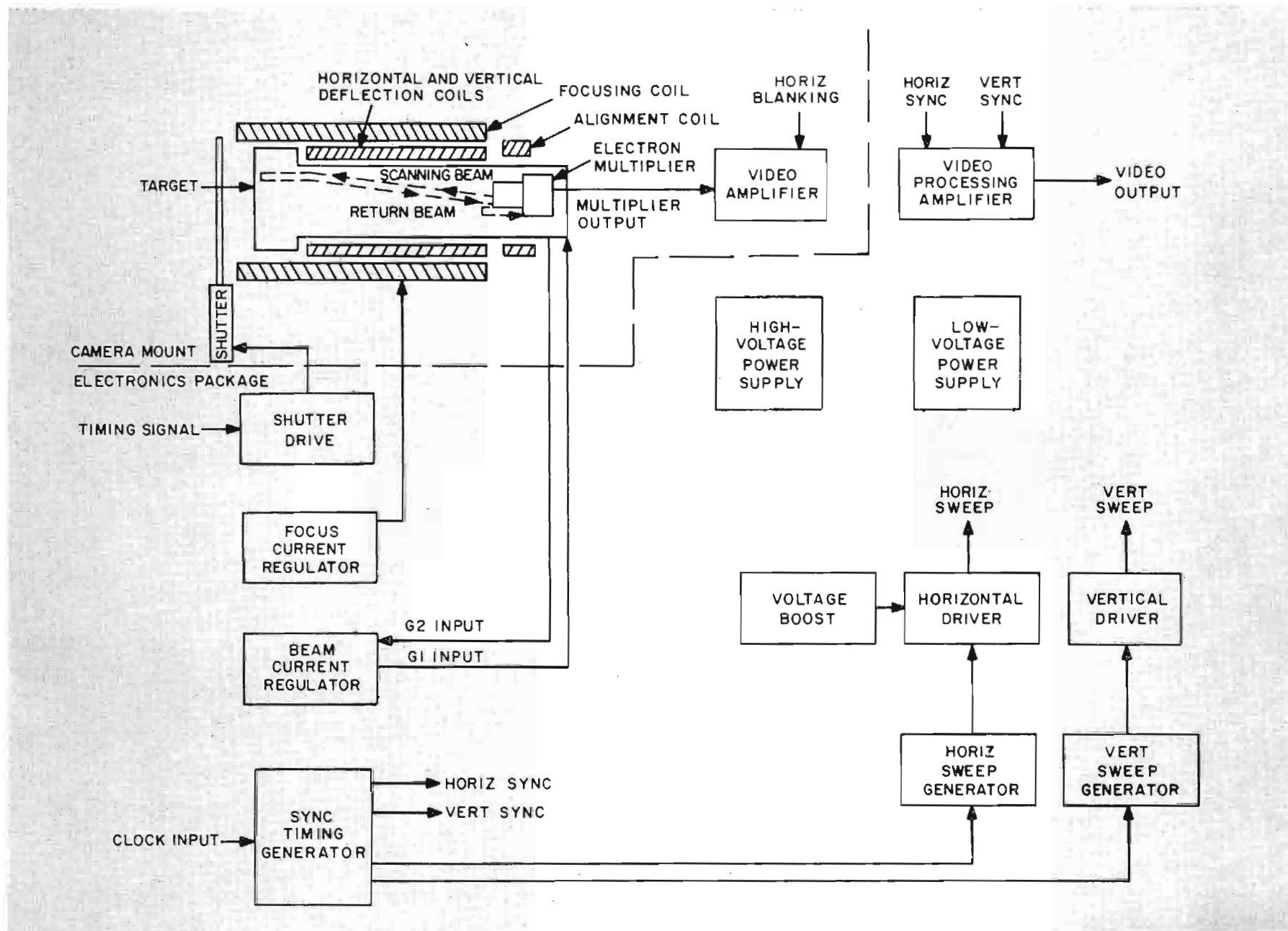

FIG. 4 Simplified Block Diagram of Return Beam Vidicon.

The laser is used since it is an extremely bright energy source consistent with wideband intensity modulation techniques. Its energy can be collected and formed into a recording spot approaching diffraction limited performance at high efficiency.

The intensity modulation of the laser is accomplished with electro-optic techniques. The light modulator accepts the laser beam and modulates its intensity in response to the video signals. This modulator uses ferroelectric electro-optic crystals to affect polarization rotation of the linearly polarized laser beam as a direct function of the applied signal voltage. Polarization modulation is connected into intensity modulation through the use of a polarization analyzer affixed to the modulator. The modulator used in the Laser Beam Image Recorder can achieve contrast ratios in excess of 100-to-1 for a change in signal of 210 Volts.

The recording spot is formed with conventional refractive components. The intensity modulated laser beam is enlarged to fill the aperture of an imaging lens. Beam enlargement is necessary since the desired aperture of the imaging lens is generally much larger than the laser beam diameter. Optical components capable of diffraction limited performance perform this function.

Scanning of the recording film is accomplished both through movement of the recording spot across the film (scanning) and film transport past the scanning station. A rotating mirror assembly is used to produce scanning of the recording medium.

Applications

The Two-Inch Return Beam Vidicon Camera System has been designed by RCA for use in an earth resources satellite.

For example, two or more of these camera systems could be carried in a modified TIROS M satellite to provide coverage of varying spectral bands. In this way, detailed information on agricultural crops, topography, forestry, water supplies, mineral resources and similar subjects could be obtained. Carried in a satellite in a 500-nautical-mile orbit, the RBV would provide a ground resolution of between 100 and 200 feet. This means that topographical features as small as 100-200 feet could be distinguished. The RBV is also sensitive enough to detect the difference between a normal crop and one that is blighted, offering the opportunity for early detection of a disease that, if continued unchecked, could destroy the entire crop. As this suggests, the earth resources applications of the RBV are virtually unlimited.

A totally new approach in TV equipment

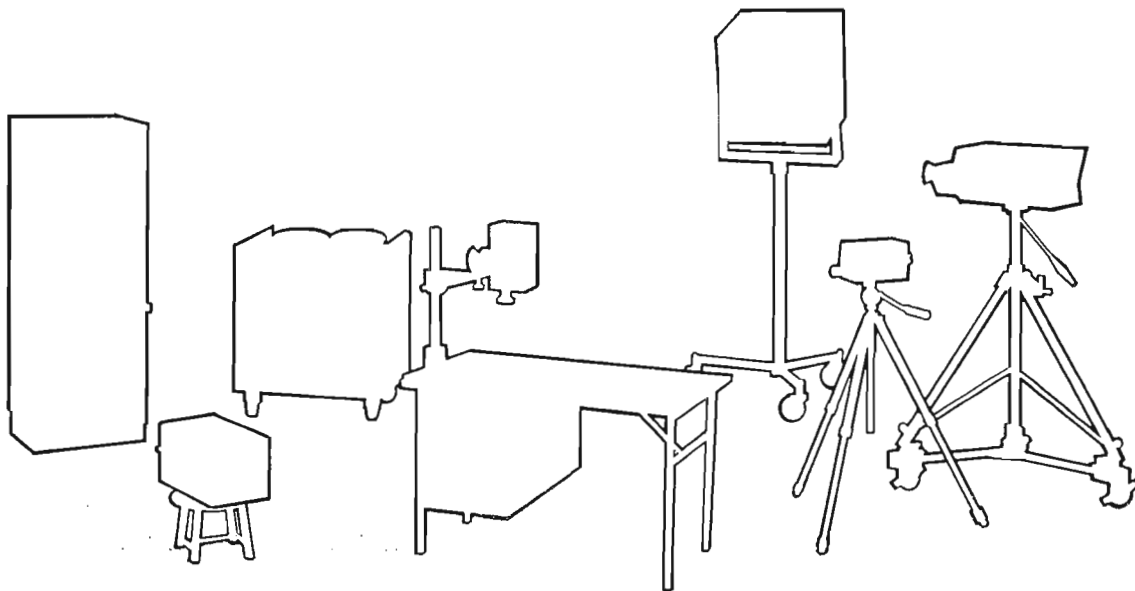

- . System Control Console—Complete audio and video control, grouped to suit your requirements.
- . TR-5 TV Tape Recorder—Puts live shows on tape.
- . PK-301 TV Camera—Mounted on stand for viewing documents or connecting to microscope.
- . PX-23 TV Video Monitor—One of complete series in 8" to 23" sizes.
- . PK-301 Transistorized Camera—Simple to operate; produces excellent pictures.
- . PK-330 TV Camera—With unique "Star Tracker" lens, viewfinder, and many broadcast quality features.

RCA PROFESSIONAL TV — the complete-family line



RCA Professional Television is an entirely new class of equipment, for educational, industrial and broadcast applications. It offers simplicity of operation, superb picture clarity, and long term reliable performance—at reasonable cost.

Today's RCA Professional Television is the most complete line of professional television equipment available. And, some new performance standards make it the most advanced, too. For example, take TV cameras. The PK-330 camera features the unique RCA "Star Tracker" lens, which enables the camera lens to tilt as it follows the subject. You move the lens *instead* of the camera—and the camera operator never has to stoop or tiptoe to keep the scene in view. The PK-330

is one of a series of compact, transistorized cameras for showing films, microscope slide enlargements and dozens of other instructional uses.

The extensive RCA camera grouping is matched by an equally complete complement of video monitors, switching systems, program control consoles, television tape recorders and related system components. As your system expands, RCA Professional equipment adds on gracefully and economically. RCA plans everything for you. RCA offers everything from camera and receiver to transmitter and recorder. The advantages: superior performance and reliability as well as one-stop responsibility for all your equipment.



The completely new 16mm Sound Projector

Until yesterday, you had to settle for good 16mm sound projectors. Now there's a great one—the RCA 1600. Before you settle for any projector, ask your Audio-Visual Distributor to demonstrate the 1600. See these new features in action:

Extra brightness makes it ideal for auditorium as well as classroom use. New optical design makes the RCA 1600 screen picture the most brilliant ever.

Full-time fidelity. All-transistor 12-watt amplifier and new super-sensitive speaker, built right into the projector case, reproduce the finest sound in 16mm.

Improved operating convenience. Reel arms you can position with one hand, instant sound, fast focus, reverse with automatic sound cut-off, 1200-foot take-up reel stored in case, and stop-on-frame option, make the 1600 the most convenient-to-use projector ever.

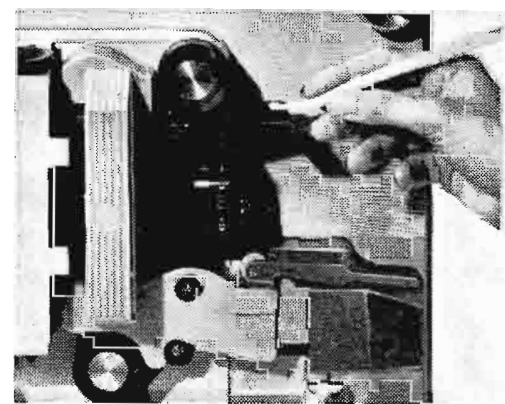

Self-threading that's carefree for you and safe for films. Optional RCA "Safe-Threader" whisks the film leader through automatically and then is disengaged so that it never touches the film.

Instructor- controlled television center



Unique RCA TELEROAMER gives teacher instant, push-button access to many learning resources for TV teaching.

Compact and versatile, the TELEROAMER is actually a simplified, small TV studio. At the touch of a button, the teacher can switch from a fixed camera shot of herself to a view of whatever is under the tabletop camera. Additional push-button switches enable the teacher to integrate into the instruction other pre-programmed materials from such sources as a TV tape recorder, films or slides, microscopic shots, etc. Tuner can also be built-in to provide off-air programs from local ETV stations.

The RCA TELEROAMER is completely mobile—it has hidden, built-in casters—and thus can be easily rolled from classroom to classroom. Now every classroom teacher can become a television teacher within

the confines of her own room—an ideal way to introduce television into *your* school.

This dynamic way to present a lesson—sequencing in a wide variety of audio visual media—can happen in *your* school this year.

Find out about the RCA TELEROAMER. It's just one more way RCA makes teaching more effective, with simple-to-operate instructional electronic systems. And, because RCA supplies every element in the system, you get system-wide performance responsibility—and centralized service. For system planning assistance, write RCA Instructional Electronics, Building 15-5, Camden, N.J. 08102.

**Because he
can't afford
2-way radio failure . . .**



**RCA's transistorized
radio assures him
full-time contact.**

If full-time contact with men on the road is as important to your business as it is to the police, look into the 2-way radio system that makes it practical.

RCA Super-Fleetfone is the transistorized mobile radio that's so troublefree it's rated for continuous duty transmitting. It is the only standard 2-way radio capable of 'round-the-clock operation without degradation in performance or expected useful life. It has no tubes to burn out, no relays to wear out.

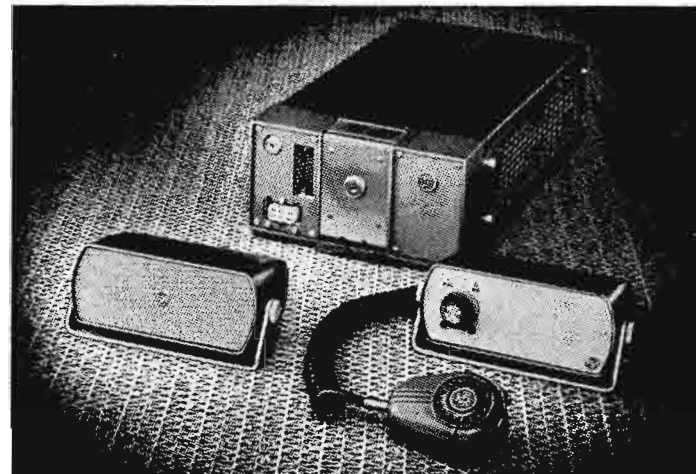

RCA proved this transistorized radio's performance in a grueling live test. After 16,000 hours of a continuous transmit test, not a single component failed in the equipment tested. The test unit is still going strong and performance continues at the original high levels.

This performance-proved equipment is available for your fleet in all frequency bands. It will pay you to investigate RCA 2-way radio . . . the instant contact system that stays on longer, and covers longer distances. Send for complete literature, or consultation on a system exactly suited to your needs.

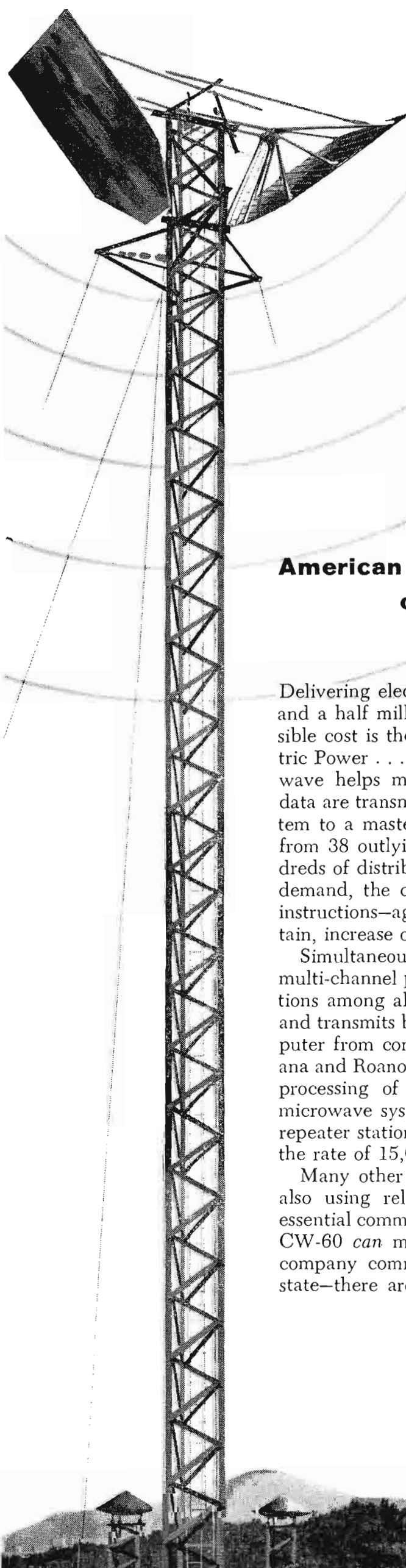

RCA microwave links electric utility's 38 generating units in 4 states

**American Electric Power controls system-wide power demand
over 1,700-mile microwave communications network**

Delivering electric service to more than five and a half million people at the lowest possible cost is the objective of American Electric Power . . . and new RCA CW-60 microwave helps make it possible. Telemetered data are transmitted over the microwave system to a master computer at Canton, Ohio, from 38 outlying generating units and hundreds of distribution points. Based on power demand, the computer automatically issues instructions—again via microwave—to maintain, increase or decrease power production.

Simultaneously, the microwave provides multi-channel private telephone communications among all points in the power system, and transmits billing data to the master computer from computers at Fort Wayne, Indiana and Roanoke, Virginia for the automated processing of customer bills. The CW-60 microwave system includes 26 terminal and repeater stations and data are transmitted at the rate of 15,000 characters per second.

Many other progressive organizations are also using reliable CW-60 microwave for essential communications and control . . . and CW-60 *can* make a big difference in *your* company communications! It's totally solid state—there are no tubes, relays or moving

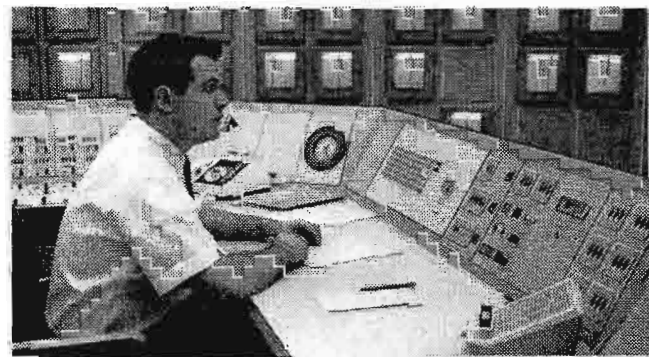

parts to fail. You get positive communications for private telephone tie-in with all of your facilities, telemetering, data transmission, closed circuit TV, teletype or any other type of communications your business requires. And RCA microwave has a built-in expansibility—add additional channels as you need them without extensive modifications to your basic system.

Get all the facts on RCA microwave—what it can do for your organization. Send the coupon to arrange a consultation with an RCA Communications Specialist . . . or to request a copy of a helpful new management booklet, "RCA Microwave—What It Is, What It Does." Find out what RCA microwave can do for you!



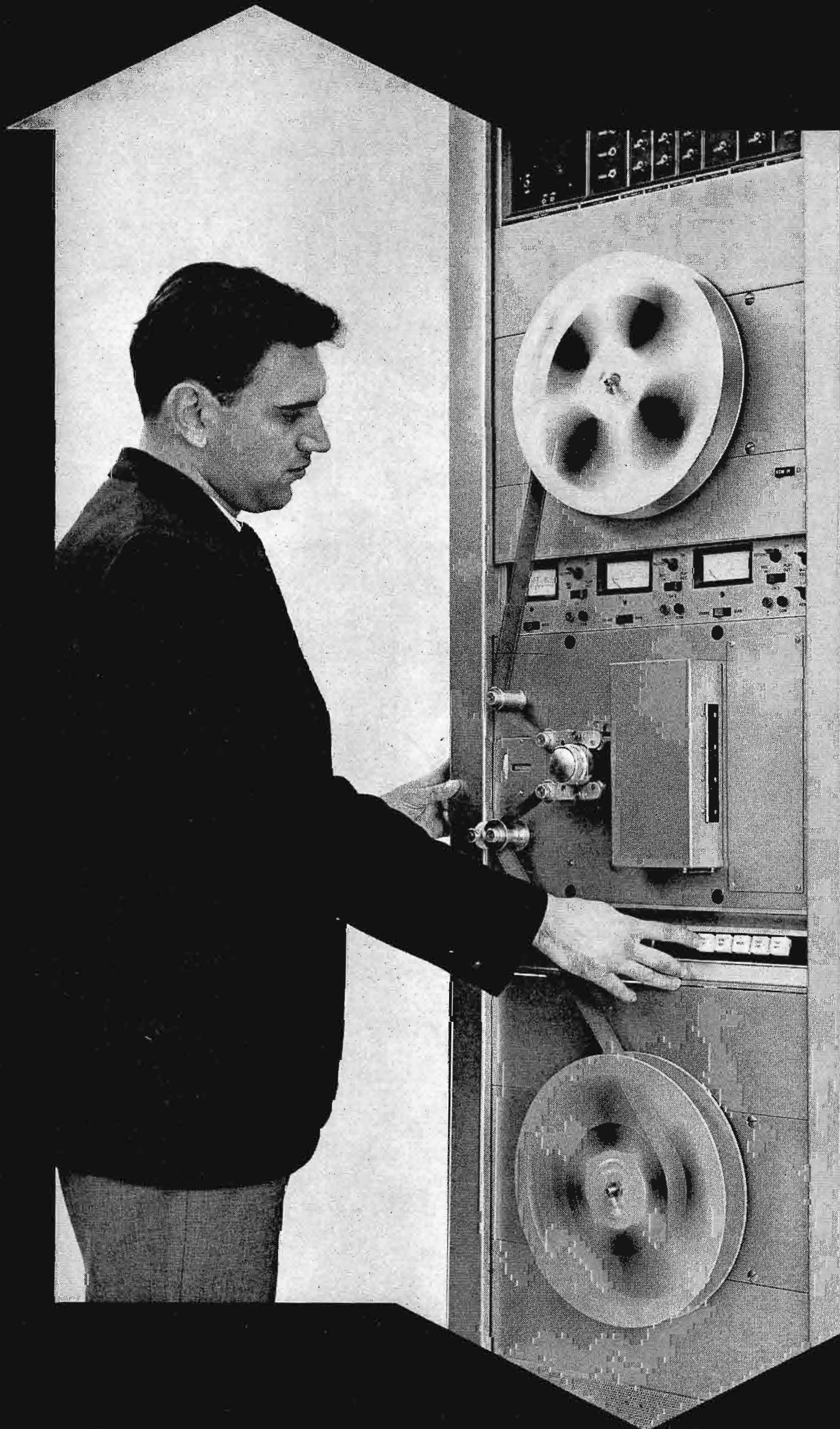

**“INSTANT”
FORWARD
OR
REVERSE
AT
1000 FPM**

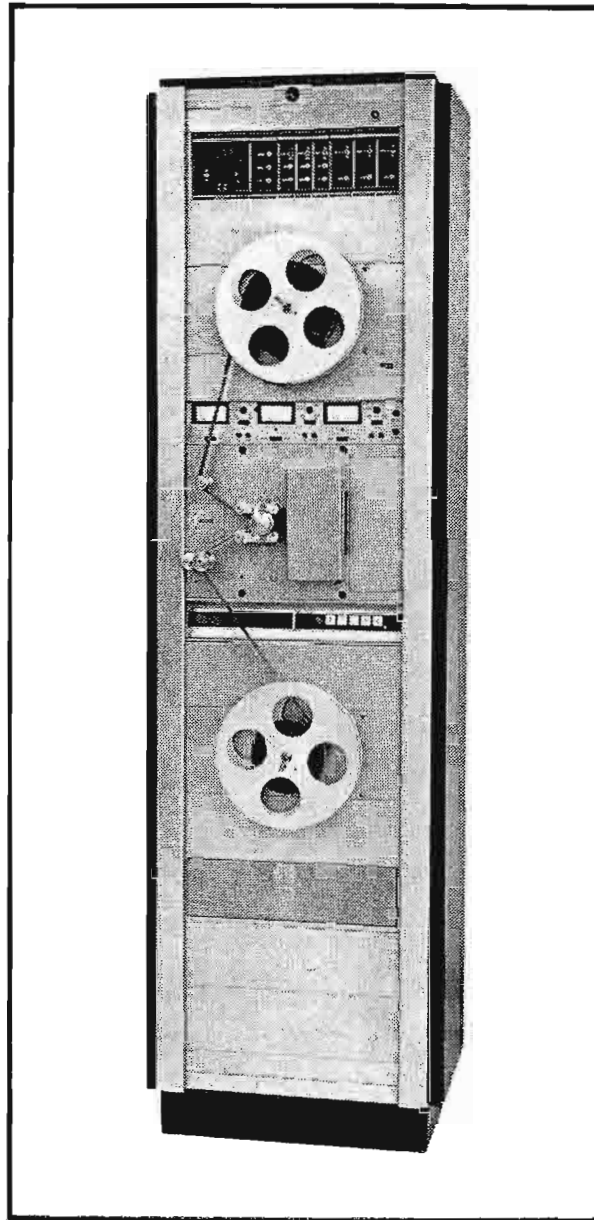

Save money and man-hours with RCA's new solid-state PM-76 TSP Magnetic Recorder/Reproducer!

Today you can rewind reel-to-reel—through the sprocket—at 1,000 fpm, completely eliminating unnecessary film handling. And that's just the first way RCA's remarkable new PM-76 brings new standards of efficiency and excellence to motion picture film recording.

In addition, it lets you update any track without audible "clicks" or any trace of fade-in or fade-out noise—thanks to unique silent, selective head

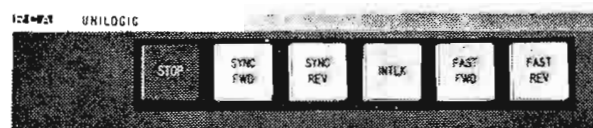

switching. To facilitate remote and automated control, there's a new logic low-voltage DC motor control—a system including tally lights for easier operation. Another innovation provides automatic head switching so that the record head also serves as the reproduce head when in the play mode.

To minimize maintenance: solid-state plug-in modules.

Now available in 1, 3, 4, and 6-track models (record/reproduce or reproduce only) for 16, 17½ or 35mm film.

For more information about the PM-76 and RCA's wide range of quality film recording equipment, Write: RCA Broadcast & Communications Products Division, 2700 W. Olive Avenue, Burbank, California, or 30 Rockefeller Plaza, New York City.

RCA service keeps all your AM, FM, TV equipment in top condition

TAKE ADVANTAGE OF THE FOLLOWING SERVICES OFFERED BY RCA:

Video Tape Recorder Service • TV Camera Overhaul • TV Transmitter Overhaul • Installation Supervision
• Microphone and Pick-Up Repairs • Transmitter Performance Measurements • Antenna Inspection Measurements
• Console Repairs • Microwave Service • TV Projector Service • Custom Fabrication • Teletypewriter Maintenance

Your audience demands a superior signal which requires top performance from all your station equipment. RCA Broadcast Service is planned to assure you of meeting this objective. More than 30 years in the broadcast industry have provided a background of solid service experience. This is the type of protection broadcasters have relied on for years, the kind of protection you can count on . . .

contract or per-call . . . from the experts in the service business, RCA Service Company. To guard performance of all your equipment . . . simply telephone one of the following field offices: Chicago (WE 9-6117), Phila. (HO 7-3300). Or contact Technical Products Service, RCA Service Company, A Division of RCA, Bldg. CHIC-225, Camden, N. J. 08101.





Color Films Come Alive

... in their Original Brilliance
with the RCA "Big Tube"
Color Film System

The "Big Tube" concept in color film cameras assures reproduction of programs and commercials in all their original beauty. Film and slide subjects have the natural look of colors that are faithfully reproduced. Pictures are brilliant, films have snap and sparkle—to entertain, to educate, and to sell.

By using a Big Tube—50% larger than others use—RCA gives you greater resolution. It's like using a big negative in photography. The picture is sharper, the focus is uniform—all over the screen. Outdoor and indoor subjects, close-ups and macro-shots, all reflect the higher resolving power.



First Choice for Color TV!

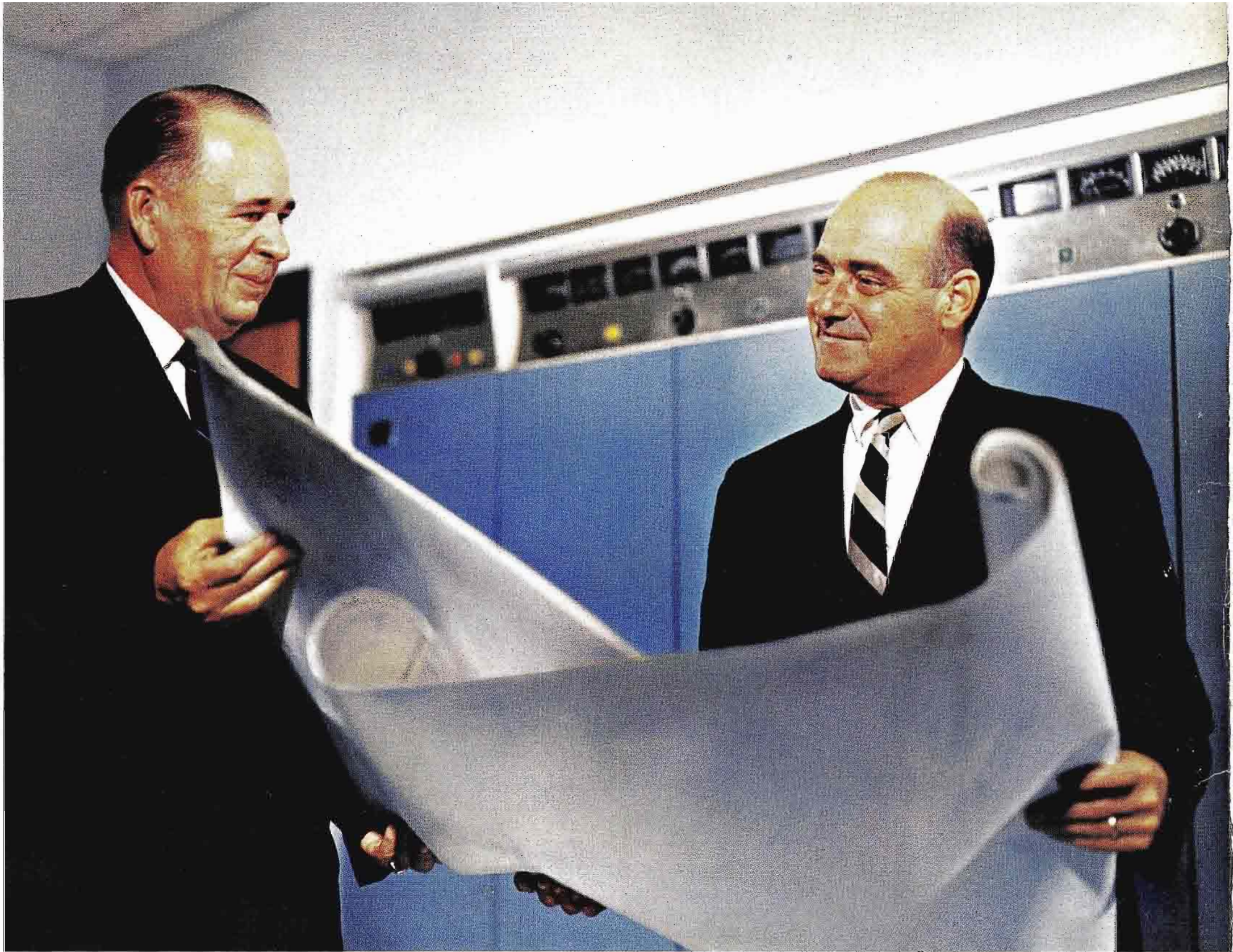

Howard L. Stalnaker, Vice President & General Manager of Meredith WOW, Inc. (right) and Glenn Flynn, Director of Engineering, discuss the completion of their new RCA transmitter facility in Omaha.

**RCA's new 25kw VHF Transmitter
is selected by WOW-TV, Omaha
for reliable color performance**